

About the Manuals

The following product manuals are available. Please use this table as a reference to request the appropriate manual as necessary.

Related Manuals

Manual Name	Manual No. (Model Code)
type A1SJH/A1SH/A2SHCPU(S1) User's manual Provides information on the performance, specifications, handling, etc. of the A1SJHCPU/A1SHCPU/A2SHCPU and on the memory cassette specifications and handling. (Optional)	IB-66779 (13JL22)
Control & Communication-Link System Master · Local module type AJ61BT11/A14SJ61BT11 User's Manual Provides information on the system configuration, performance specifications, handling, wiring and troubleshooting of the AJ61BT11 and A1SJ61BT11. (Optional)	IB-66721 (13J872)
type ACPU Programming Manual (Fundamentals) Provides information on the programming procedures, device names, parameters, programming types and memory area structure required for programming. (Optional)	IB-66249 (13J740)
type ACPU Programming Manual (Common Instructions) Provides information on the sequence instructions, basic instructions and application instructions and how to use microcomputer programs. (Optional)	IB-66250 (13J741)

Precautions Regarding Safety

(Always read this instruction before using the equipment)

Before using this product, please read the manuals supplied with the products and the relevant manuals introduced in the supplied manuals carefully, and take sufficient safety precautions to handle the products correctly.

Please keep the supplied manuals carefully so that they may be available when required and always forward them to the end user.

Revisions

*The manual number is noted at the lower left of the back cover.

Print Date	*Manual Number	Revision
Oct. 1997	IB(NA)-66816-A	First printing

This manual confers no industrial property rights or any rights of any other kind, nor does it confer any patent licenses. Mitsubishi Electric Corporation cannot be held responsible for any problems involving industrial property rights which may occur as a result of using the contents noted in this manual.

CONTENTS

About the Manuals

1. INTRODUCTION	1-1
2. HOW TO WRITE THE CC-LINK DEDICATED INSTRUCTIONS	2-1
3. CC-LINK DEDICATED INSTRUCTIONS	3-1 to 3-45
3.1 Instructions for Use of the CC-Link Dedicated Instructions	3- 2
3.2 Network Parameter Setting	RLPA 3- 3
3.3 Automatic Refresh Parameter Setting	RRPA 3- 7
3.4 Read from Automatic Updating Buffer Memory	RIFR 3-13
3.5 Write to Automatic Updating Buffer Memory	RITO 3-15
3.6 Read from Remote Station Buffer Memory	RIRD 3-19
3.7 Write to Remote Station Buffer Memory	RIWT 3-23
3.8 Read from Intelligent Device Station Buffer Memory (with Handshake)	RIRCV 3-27
3.9 Write to Intelligent Device Station Buffer Memory (with Handshake)	RISEND 3-31
3.10 Read from Remote Device Station	RDGET 3-35
3.11 Write to Remote Device Station	RDPUT 3-39
3.12 Monitoring of Remote Device Station	RDMON 3-43

1 .INTRODUCTION

This manual provides information on the formats, functions and programming of CC-Link dedicated instructions added to the A1SJHCPU/ A1SHCPU/ A2SHCPU.*1

There are the following 11 different CC-Link dedicated instructions (refer to Chapter 3).

- Network parameter setting
- Automatic refresh parameter setting
- Read from automatic update buffer
- Write to automatic update buffer
- Read from remote station buffer memory*2
- Write to remote station buffer memory*2
- Read from intelligent device station buffer memory
- Write to intelligent device station buffer memory
- Read from remote device station
- Write to remote device station
- Remote device station monitoring

Refer to the following manual for the performance, specifications, handling and other information of the A1SJHCPU/A1SHCPU/A2SHCPU.

- type A1SJH/A1SH/A2SHCPU(S1) Use's Manual

Also refer to the following manuals for the specifications of the sequence, basic and application instructions available for the A1SJHCPU /A1SHCPU /A2SHCPU and for the specifications of CC-Link.

- For the specifications of the sequence, basic and application instructions
type ACPU Programming Manual (Common Instructions)
- For the specifications of CC-Link
Control & Communication-Link System Master-Module
type AJ65BT11 / A1SJ61BT11 User's Manual

REMARKS

- 1) *1:In this manual, the A1SJHCPU, A1SHCPU and A2SHCPU are generically called the AnSHCPU.
- 2) *2:In this manual, the local station and intelligent device station are generically called the remote station.

2. HOW TO WRITE THE CC-LINK DEDICATED INSTRUCTIONS

Write a CC-Link dedicated instruction in combination with the LEDA, LEDB, LEDC and SUB instructions.

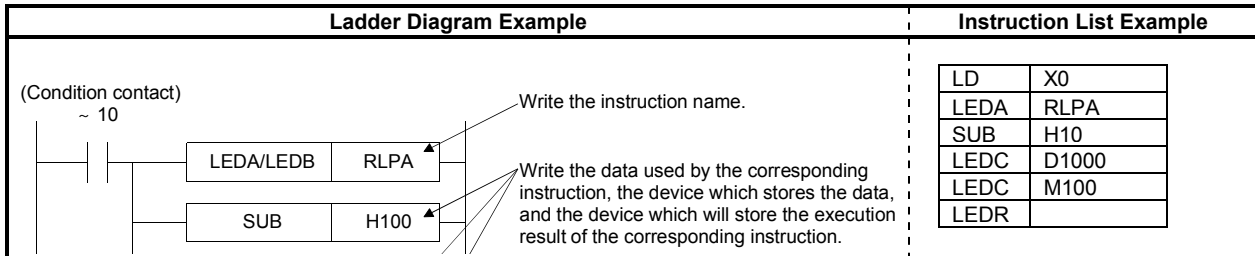

(1) LEDA/LEDB RLPA

Indicates the beginning of the dedicated instruction.

- LEDA Instruction name ••• The instruction is executed every scan while the condition contact is on.
- LEDB Instruction name ••• The instruction is executed only once on the leading edge (OFF→ON) of the condition contact.

(2) SUB H10

Set 16-bit data used by the corresponding instruction.

When using "SUB", use a constant (K/H) to set the data.

(3) LEDC D1000 / LEDC M100

- Set the device which stores the data used by the corresponding instruction or the device which will store the execution result of the corresponding instruction.
- When using "LEDC", specify a bit device or a word device.
For bit devices/word devices available, refer to the "Available Device" list for the corresponding instruction.
- Before execution of the instruction, store the data used by the corresponding instruction.
Also, the data already set should not be changed during execution of the instruction.

(4) LEDR

Indicates the end of the dedicated instruction.

3. CC-LINK DEDICATED INSTRUCTIONS

The instructions dedicated to CC-Link are designed to make automatic refresh setting for the AnSHCPU and master module/local module and to make data communication with a remote station connected to CC-Link. There are 11 different CC-Link dedicated instructions as indicated in Table 3.1.

Table 3.1 CC-Link Dedicated Instruction List

Classification	Instruction Name	Description	Instruction Execution Stations		Stations Connected to CC-Link				Refer To
			M	L	M	L	ID	RD	
Network parameter setting	RLPA	Sets the network parameters to the master module of CC-Link.	O	×	×	×	×	×	Section 3.2
Automatic refresh parameter setting	RRPA	Sets the automatic refresh parameters to the master/local module of CC-Link.	O	O	×	×	×	×	Section 3.3
Read from automatic updating buffer memory	RIFR	Reads the specified points of data from the automatic updating buffer memory of the master/local module.	O	O	×	×	×	×	Section 3.4
Write to automatic updating buffer memory	RITO	Writes the specified points of data to the automatic updating buffer memory of the master/local module.	O	O	×	×	×	×	Section 3.5
Read from remote device station buffer memory	RIRD	Reads the specified points of data from the specified buffer memory of the remote device station.	O	O	O	O	O	×	Section 3.6
Write to remote device station buffer memory	RIWT	Writes the specified points of data to the specified buffer memory of the remote device station.	O	O	O	O	O	×	Section 3.7
Read from intelligent device station buffer memory (with handshake)	RIRCV	Reads the specified points of data from the specified buffer memory of the intelligent device station. Handshake is performed using a handshake signal.	O	×	×	×	O	×	Section 3.8
Write intelligent device station buffer memory (with handshake)	RISEND	Writes the specified points of data to the specified buffer memory of the intelligent device station. Handshake is performed using a handshake signal.	O	×	×	×	O	×	Section 3.9
Read from remote device station	RDGET	Reads data from a remote device station.	O	×	×	×	×	O	Section 3.10
Write to remote device station	RDPUT	Writes data to a remote device station.	O	×	×	×	×	O	Section 3.11
Remote device station monitoring	RDMON	Monitors a remote device station.	O	×	×	×	×	O	Section 3.12

REMARKS

1) "M", "L", "ID" and "RD" in Table 3.1 denote the following:

- M : Master station
- L : Local station
- ID : Intelligent device station
- RD : Remote device station

2) In the "Instruction Execution Stations" and "Object Stations" fields of Table 3.1, O denotes that the corresponding station is available and × unavailable.

However, since the availability of the dedicated instructions in Table 3.1 changes with the module of the station connected to CC-Link, refer to the manual of the module used to confirm the availability.

3.1 Instructions for Use of the CC-Link Dedicated Instructions

- (1) Different intelligent device stations have different buffer memory capacities.
Refer to the manual of the intelligent device station used.
- (2) Only one of the RIRD, RIWT, RISEND and RIRCV instructions may be executed for the same station.
If two or more of the RIRD, RIWT, RISEND and RIRCV instructions are executed, the second and subsequent instructions are ignored.
- (3) RDGET, RDPUT and RDMON may be executed for the same station separately.
Any of these instructions cannot be executed in two or more locations for the same station.
If any of RDGET, RDPUT and RDMON instructions is used in two or more places, the second and subsequent instructions are ignored.
- (4) RIRD, RIWT, RISEND, RIRCV, RDGET, RDPUT and RDMON may be executed for different stations at the same time.
Note that up to 64 instructions may be executed simultaneously.
- (5) The data of any device used by the CC-Link dedicated instruction should not be changed until the completion of the instruction.
If the data of the device is changed during execution of the instruction, the CC-Link dedicated instruction cannot be completed properly.
- (6) Specify the head I/O number of the master/local module in the CC-Link dedicated instruction.
This head I/O number of the master/local module is the value in the upper 2 digits of the master/local module's I/O number represented in 3 digits.
For example, when the master/local module's I/O number is X/Y120, the head I/O number is 12_H.

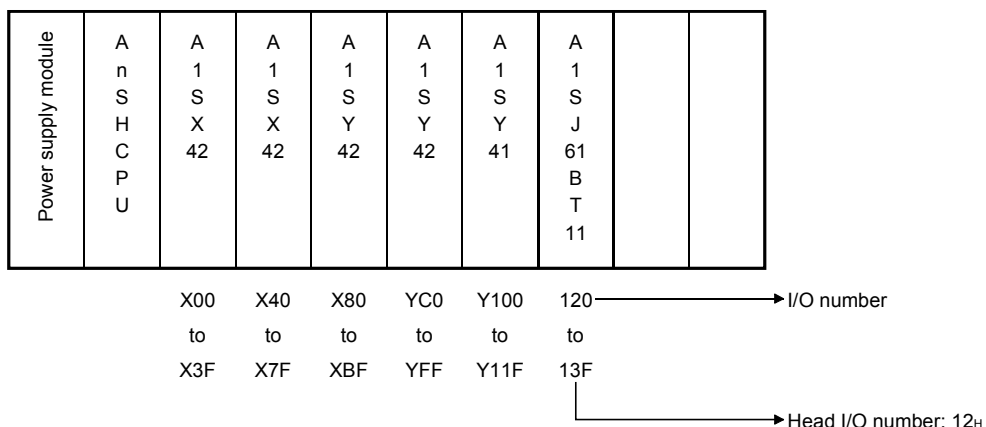

3.2 Network Parameter Setting RLPA

	Available Devices																	Digit designation	Number of steps	Subset	Index	Carry flag	Error flag					
	Bit Device							Word Device							Constant	Pointer	Level											
	X	Y	M	L	S	B	F	T	C	D	W	R	A0	A1										Z	V	K	H	P
(n)																	O	O										
(D1)								O	O	O	O	O																
(D2)		O	O	O	O	O																						

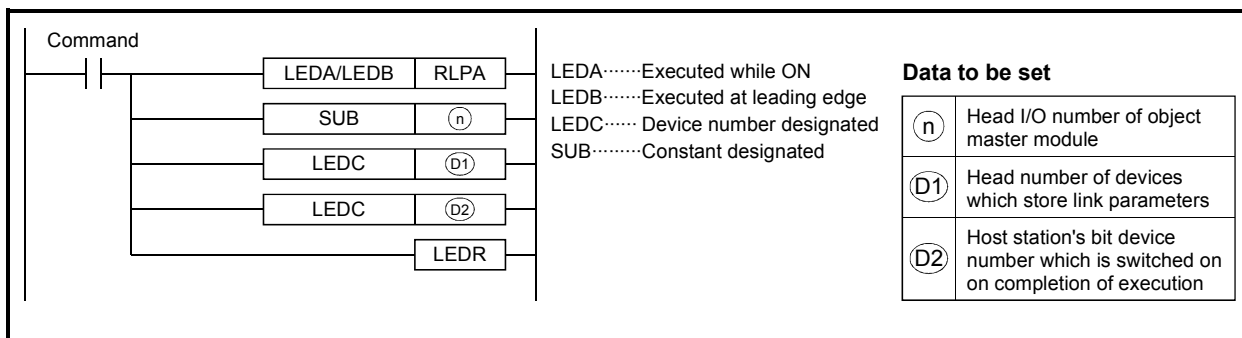

Network Parameter Data (1) Network parameter setting items

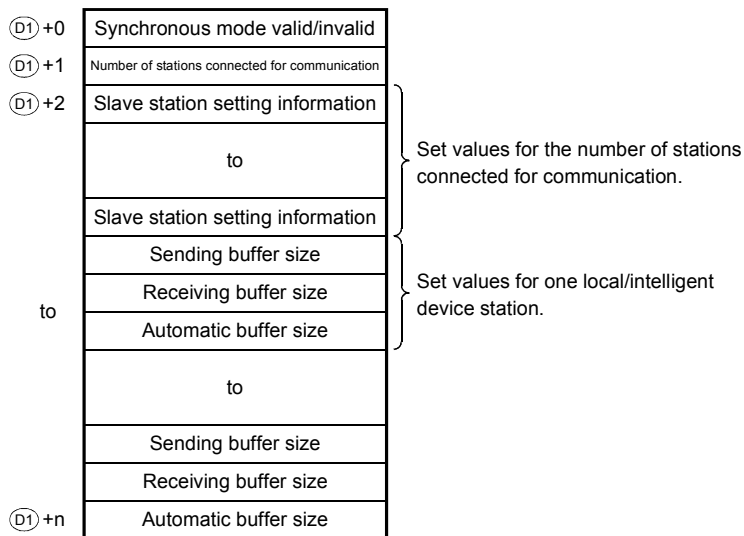

- (2) Number of points required for the network parameter area
- The following points are required for the network parameter setting:
- Synchronous mode 1 point valid/invalid setting
 - Communication station..... 1 point count setting
 - Slave station setting Number of points for the number of slave stations connected for communication
 - Sending buffer size Number of points for the number of local and intelligent device stations
 - Receiving buffer size Number of points for the number of local and intelligent device stations
 - Automatic update Number of points for the number of local and intelligent device stations

(3) Network parameter settings

Item	Set Data	Setting Range	Setting End								
Synchronous mode valid/invalid	Set whether the synchronous mode is valid or invalid. <ul style="list-style-type: none"> When synchronous mode is valid: 0 When synchronous mode is invalid: 1 	0/1	User								
Number of stations connected for communication	Set the number of slave stations connected to the master module of CC-Link.	1 to 64	User								
Slave station setting information	Set the slave station type, number of slave stations occupied, and station number as indicated below: b15 to b12 b11 to b8 b7 to b0 	—	User								
	<ul style="list-style-type: none"> Station number setting 1 to 64 • Setting with BIN • 	b0 to b7 1 to 64 (1H to 40H)									
	<ul style="list-style-type: none"> Set the number of slave stations occupied <table border="1"> <thead> <tr> <th>Number of slave stations occupied</th> <th>Setting</th> </tr> </thead> <tbody> <tr> <td>1 station</td> <td>1</td> </tr> <tr> <td>2 station</td> <td>2</td> </tr> <tr> <td>3 station</td> <td>3</td> </tr> <tr> <td>4 station</td> <td>4</td> </tr> </tbody> </table>	Number of slave stations occupied		Setting	1 station	1	2 station	2	3 station	3	4 station
Number of slave stations occupied	Setting										
1 station	1										
2 station	2										
3 station	3										
4 station	4										
	<ul style="list-style-type: none"> Slave station type setting <table border="1"> <thead> <tr> <th>Slave Station Type</th> <th>Setting</th> </tr> </thead> <tbody> <tr> <td>Remote I/O station</td> <td>0</td> </tr> <tr> <td>Remote device station</td> <td>1</td> </tr> <tr> <td>Local station</td> <td rowspan="2">2</td> </tr> <tr> <td>Intelligent device station</td> </tr> </tbody> </table>	Slave Station Type	Setting	Remote I/O station	0	Remote device station	1	Local station	2	Intelligent device station	b12 to b15 0 to 2
Slave Station Type	Setting										
Remote I/O station	0										
Remote device station	1										
Local station	2										
Intelligent device station											
Sending buffer size	Set the number of points transmitted from the master station to a local/intelligent device station.	*	User								
Receiving buffer size	Set the number of points transmitted from a local/intelligent device station to the master station.	*	User								
Automatic updating buffer size	Set the number of points of the automatic updating buffer used by the master station and local/intelligent device station.	*	User								

*: To be set in response to the module used.

Functions

- (1) When the RLPA instruction is executed, the network parameter data set to the devices beginning with the one specified at (D1) is set to the master module specified at (n).

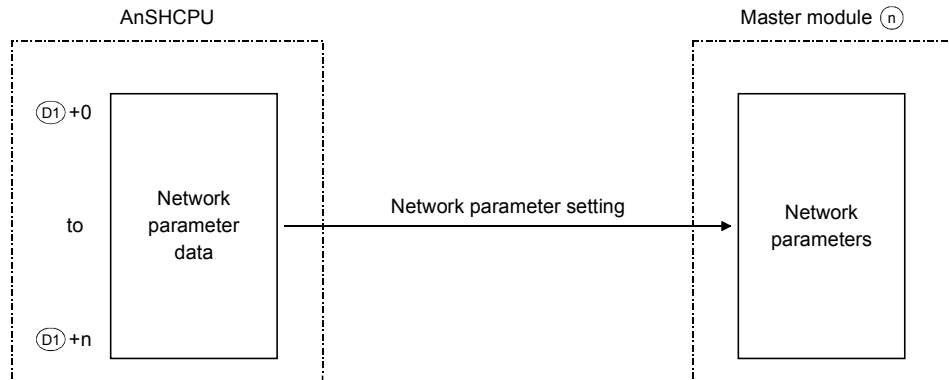

- (2) When the slave station type specified is a local/intelligent device station, it is necessary to set the "sending buffer size", "receiving buffer size" and "automatic updating buffer size". When the slave station type is a remote I/O station or a remote device station, it is not necessary to set the "sending buffer size", "receiving buffer size" and "automatic updating buffer size".

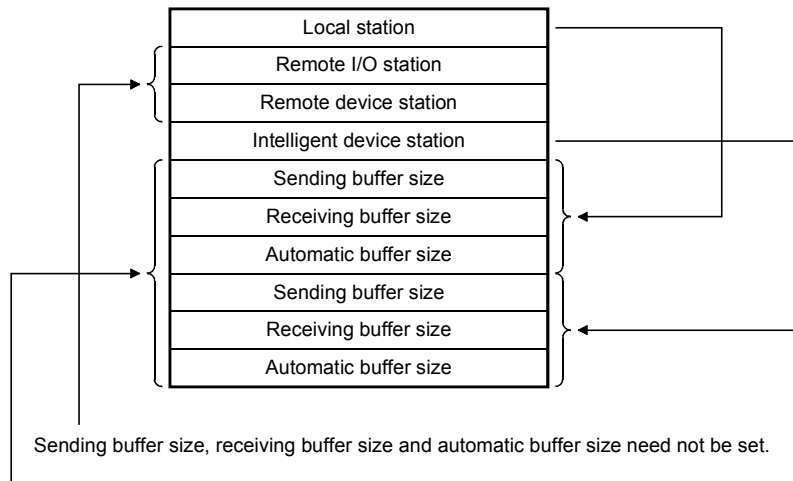

Set sizes for local and intelligent device stations successively.
 (For remote I/O and remote device stations, their buffer sizes are not set.
 When setting for the other stations, therefore, start setting with the frontmost empty position.)

- (3) After setting of the network parameters, if the RLPA instruction is executed again during RUN to change the network parameters, new data is not used for communication with the slave stations. When the AnSHCPU is switched to STOP/PAUSE, then to RUN, the new network parameters are used for communication with the slave stations.

Execution Conditions

As shown below, when the LEDA instruction is used, the RLPA instruction is executed every scan while the write command is ON. When the LEDB instruction is used, the RLPA instruction is executed only one scan on the leading edge (OFF → ON) of the write command.

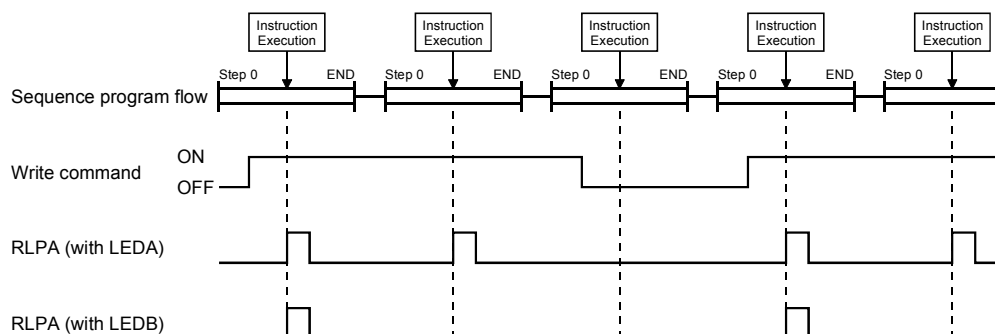

Program Example

The following program sets the network parameters to the master module of CC-Link allocated to I/O numbers 000 to 01F.

(1) Network parameter settings

Set Item		Set Data		Device for Storing Data
Synchronous mode valid/invalid setting		Synchronous mode	1	D1000
Communication station count setting		1 module	1	D1001
Slave station setting information	Slave station type	Intelligent device station	2	D1002
	Number of slave stations occupied	1 station	1	
	Station number	1	1	
Sending buffer size		128 (80H) words		D1003
Receiving buffer size		128 (80H) words		D1004
Automatic buffer size		960 (600H) words		D1005

(2) Program

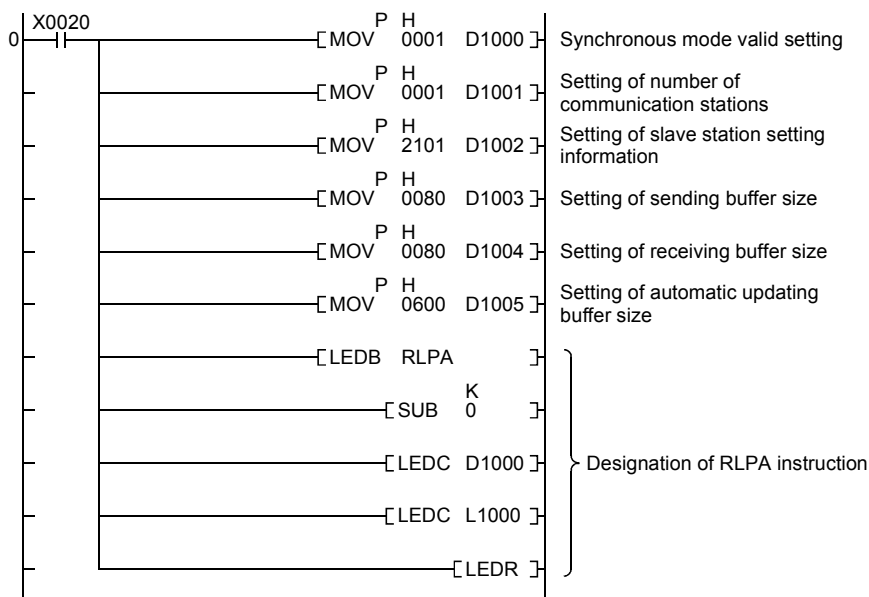

3.3 Automatic Refresh Parameter Setting RRP

	Available Devices																Digit designation	Number of steps	Subset	Index	Carry flag	Error flag						
	Bit Device							Word Device							Constant	Pointer							Level					
	X	Y	M	L	S	B	F	T	C	D	W	R	A0	A1										Z	V	K	H	P
(n)																	O	O										
(D)								O	O	O	O	O												20				O

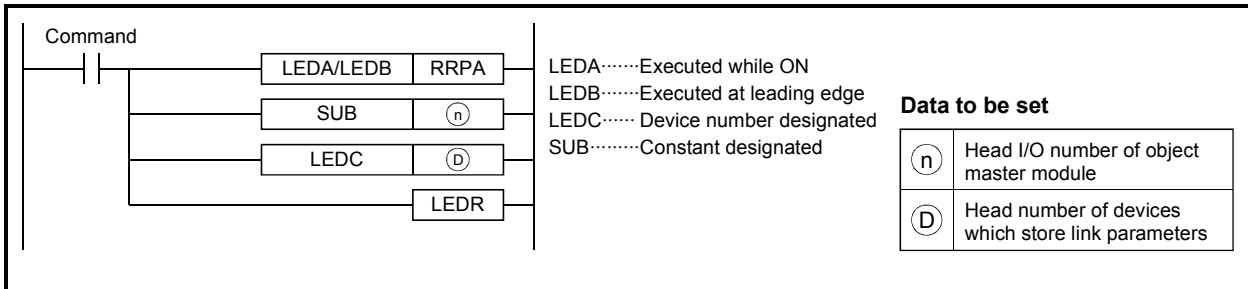

Automatic Refresh Parameter Data

(1) Automatic refresh parameter setting items

(D) + 0	RX's head number	RX refresh range setting
(D) + 1	AnSHCPU side refreshed device code	
(D) + 2	AnSHCPU side refreshed device's head number	
(D) + 3	Number of refresh points	
(D) + 4	RY's head number	RY refresh range setting
(D) + 5	AnSHCPU side refreshed device code	
(D) + 6	AnSHCPU side refreshed device's head number	
(D) + 7	Number of refresh points	
(D) + 8	RW's head number	RW refresh range setting
(D) + 9	AnSHCPU side refreshed device code	
(D) + 10	AnSHCPU side refreshed device's head number	
(D) + 11	Number of refresh points	
(D) + 12	SB's head number	SB refresh range setting
(D) + 13	AnSHCPU side refreshed device code	
(D) + 14	AnSHCPU side refreshed device's head number	
(D) + 15	Number of refresh points	
(D) + 16	SW's head number	SW refresh range setting
(D) + 17	AnSHCPU side refreshed device code	
(D) + 18	AnSHCPU side refreshed device's head number	
(D) + 19	Number of refresh points	

- (2) Points for automatic refresh parameter area
 Automatic refresh parameter data occupies 20 points from (D1) +0 to (D1) +19.
 When there is a device on which automatic refresh will not be performed (RX, RY, RW, SB, SW), set "0" to its refreshed device code or number of refresh points.

(3) Automatic refresh parameter settings

Item	Set Data	Setting End																				
RX's head number	Set the head number of RX on the master/local module side.	System																				
RY's head number	Set the head number of RY on the master/local module side.	User																				
RW's head number	Set the head number of RW on the master/local module side.	RWr•System RWw•User																				
SB's head number	Set the head number of SB on the master/local module side.	System																				
SW's head number	Set the head number of SW on the master/local module side.	System																				
AnSHCPU side refreshed device code	Set the AnSHCPU side device with the following device code: <table border="1" style="margin-left: 20px;"> <tr> <td>Device name</td> <td>X</td> <td>Y</td> <td>M</td> <td>B</td> <td>T</td> <td>C</td> <td>D</td> <td>W</td> <td>R</td> </tr> <tr> <td>Device code</td> <td>1</td> <td>2</td> <td>3</td> <td>4</td> <td>5</td> <td>6</td> <td>7</td> <td>8</td> <td>9</td> </tr> </table> 0: No automatic refresh setting	Device name	X	Y	M	B	T	C	D	W	R	Device code	1	2	3	4	5	6	7	8	9	User
Device name	X	Y	M	B	T	C	D	W	R													
Device code	1	2	3	4	5	6	7	8	9													
AnSHCPU side refreshed device's head number	Set the head device number on the AnSHCPU side.	User																				
Number of refresh points	Set the number of points on which automatic refresh will be performed. 0: No automatic refresh setting	User																				

Functions

- (1) Set the devices and numbers of points on which automatic refresh will be performed between the AnSHCPU and master/local module. When the FROM/TO instruction is used to read/write data from/to the master/local module, the RRPA instruction need not be executed.

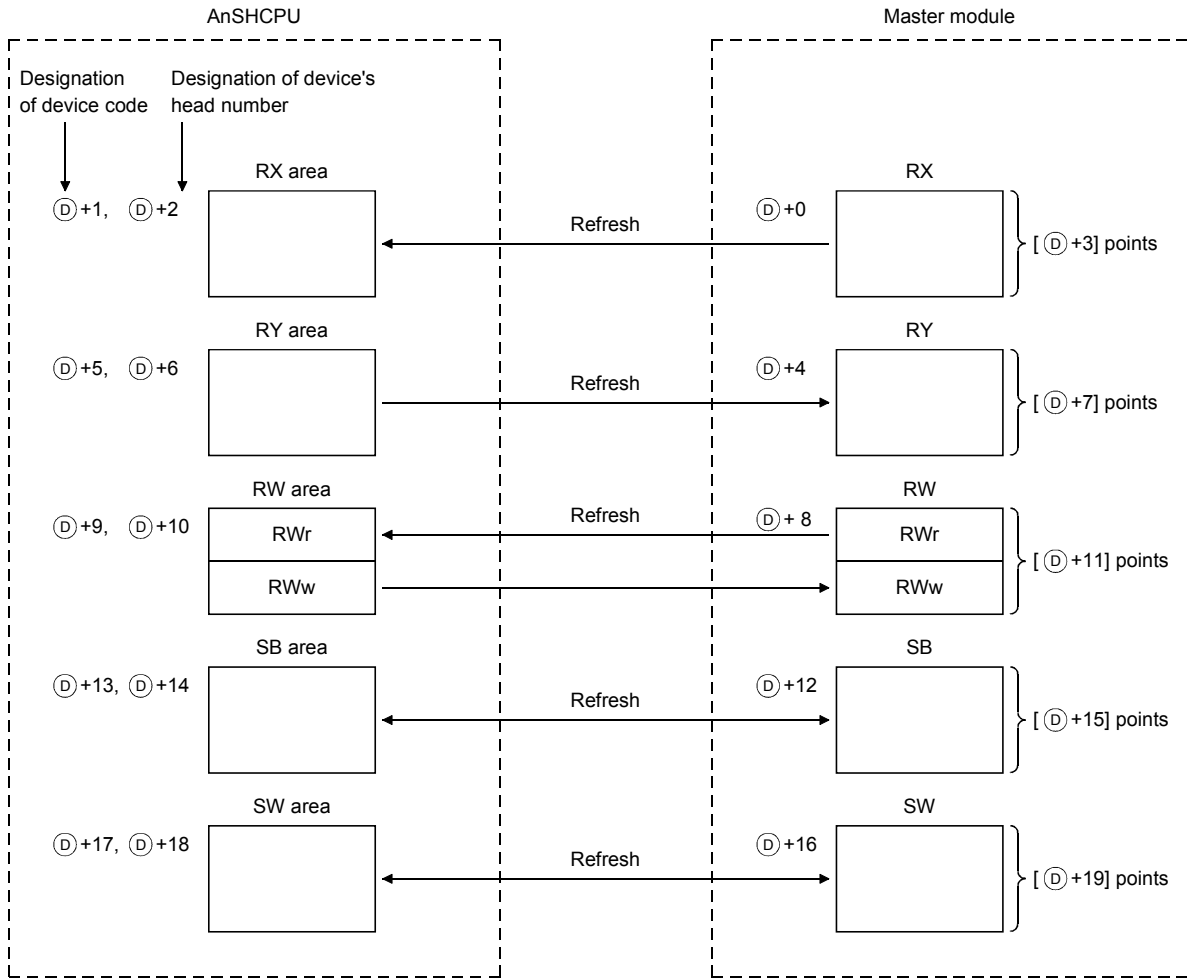

- (2) When the RRPA instruction is executed, the automatic refresh settings are registered to the AnSHCPU and automatic refresh is performed between the AnSHCPU and master/local module.

(3) The following table indicates whether refreshed devices may be set or not.

Refreshed Device	Device Code	Setting				
		RX	RY	RW	SB	SW
X ^{*1}	1	O	O	O	O	O
Y ^{*1}	2	O	O	O	O	O
M(L, S)	3	O	O	O	O	O
B ^{*2}	4	O	O	O	O	O
T	5	O	O	O	O	O
C	6	O	O	O	O	O
D	7	O	O	O	O	O
W ^{*2}	8	O	O	O	O	O
R	9	O	O	O	×	×

O: May be set, ×: Cannot be set

REMARKS

*1: Set the range which is not being used by the main base, extension base and data link.

*2: Set B and W in the range not used by data link.

(4) If the automatic refresh parameters are changed (RRPA instruction is executed) during RUN, new data is not used for control. When the AnSHCPU is switched to STOP/PAUSE, then to RUN, the new automatic refresh parameters are used for refreshing.

(5) Set RWr and RWw areas in the RW area. Since the RWw area is set after the RWr area reserved for 64 stations, set RWw as shown below.

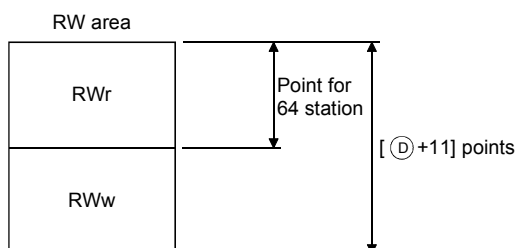

- (6) Instructions for setting refreshed device in SB and SW
- (a) In SB and SW, set refreshed devices within the specified number of points starting from the head number. SB0000 to SB003F are refreshed from the AnSHCPU to the master module, and SB0040 to SB00FF are refreshed from the master module to the AnSHCPU.
 - (b) File registers (R) cannot be specified as refreshed devices in SB and SW. If file registers are set in SB or SW and the AnSHCPU, an instruction code error occurs and the AnSHCPU is inoperative.
 - (c) The device range set for refreshed devices in SB or SW should not be specified as a latch range.
 - (d) The SB and SW refresh ranges set with the RRPA instruction during power-on cannot be changed.

Execution Conditions

As shown below, when the LEDA instruction is used, the RRPA instruction is executed every scan while the write command is ON. When the LEDB instruction is used, the RRPA instruction is executed only one scan on the leading edge (OFF → ON) of the write command.

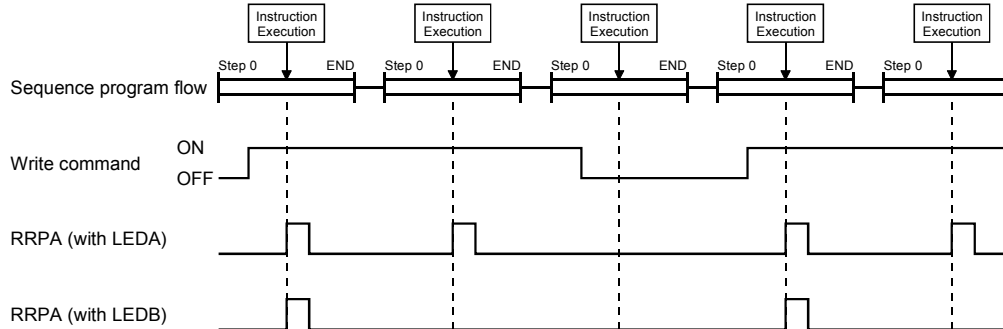

Operation Errors

Any of the following conditions will result in an operation error and the error flag (M9011) switch on.

Description	Error Code	
	D9008	D9092
The device code specified is 0 or other than 1 to 9	50	503
The head number of a bit device is not a multiple of 16		
The number of refresh points is not a multiple of 16		

Program Example

The following program sets the automatic refresh parameters to the master module of CC-Link allocated to I/O numbers 000 to 01F.

(1) Automatic refresh parameter settings and data storage devices

Setting Item	Set Data	Data Storage Device
RX's head number	0	D1000
AnSHCPU side refreshed device code	X (1)	D1001
AnSHCPU side refreshed device's head number	A0H	D1002
Number of refresh points	32	D1003
RY's head number	0	D1004
AnSHCPU side refreshed device code	Y (2)	D1005
AnSHCPU side refreshed device's head number	A0H	D1006
Number of refresh points	48	D1007
RW's head number	0	D1008
AnSHCPU side refreshed device code	D (7)	D1009
AnSHCPU side refreshed device's head number	160 (A0H)	D1010
Number of refresh points	272	D1011
SB's head number	0	D1012
AnSHCPU side refreshed device code	M (3)	D1013
AnSHCPU side refreshed device's head number	160 (A0H)	D1014
Number of refresh points	256	D1015
SW's head number	0	D1016
AnSHCPU side refreshed device code	W (8)	D1017
AnSHCPU side refreshed device's head number	A0H	D1018
Number of refresh points	256	D1019

(2) Program example

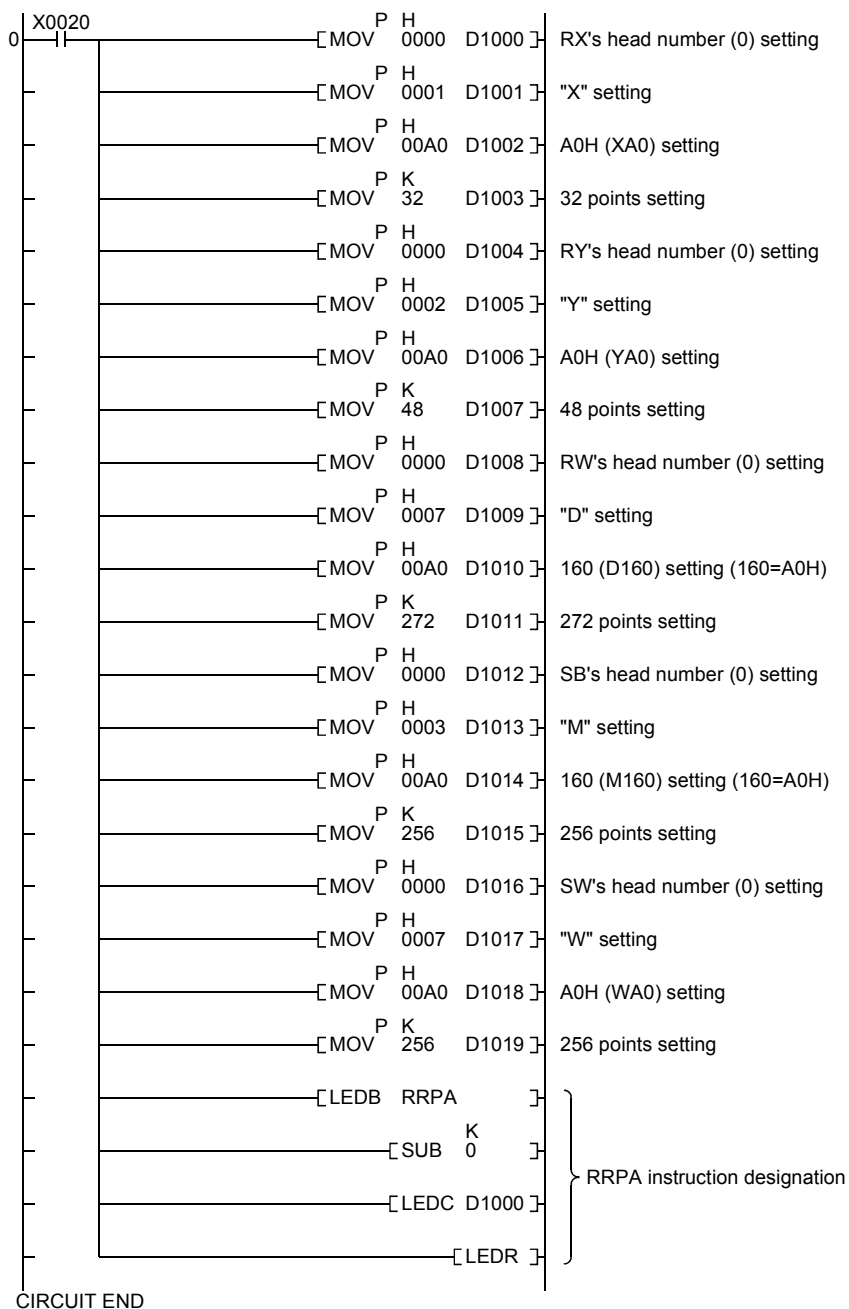

3.4 Read from Automatic Updating Buffer Memory RIFR

	Available Devices																Digit designation	Number of steps	Subset	Index	Carry flag	Error flag						
	Bit Device							Word Device							Constant	Pointer							Level					
	X	Y	M	L	S	B	F	T	C	D	W	R	A0	A1										Z	V	K	H	P
(n1)																O	O					29						
(n2)								O	O	O	O	O			O	O												
(n3)								O	O	O	O	O			O	O												O
(D)								O	O	O	O	O																
(n4)								O	O	O	O	O			O	O												

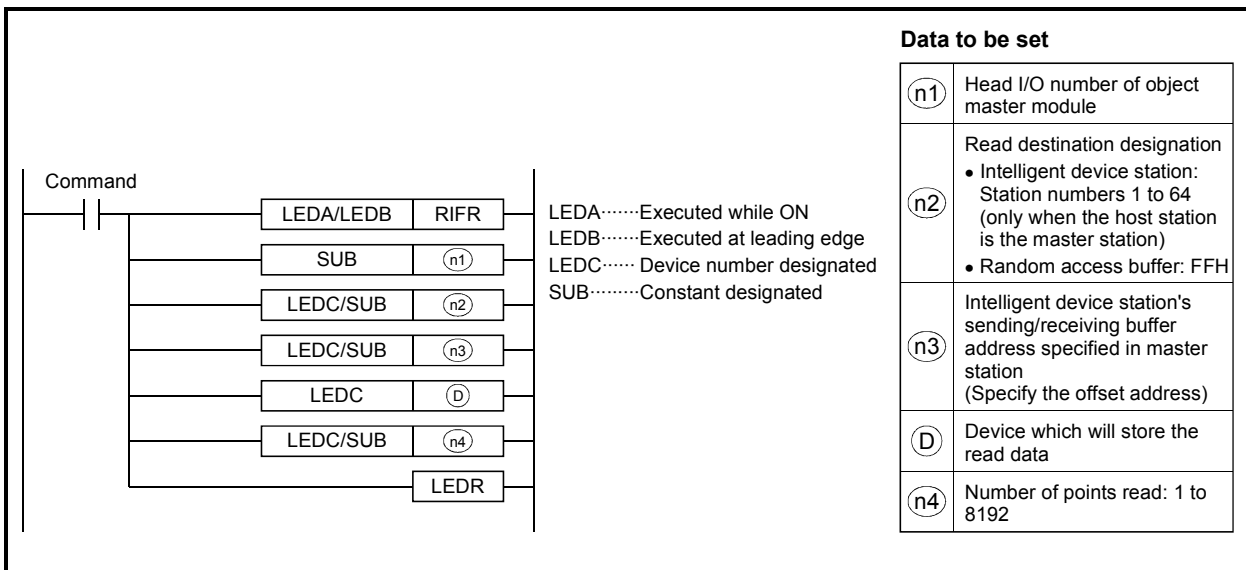

Functions

- (1) Reads the points of data specified at (n4) from the automatic updating buffer memory address specified at (n3) for the station having the station number specified at (n2) in the master module specified at (n1) and stores that data into the devices starting from the one specified at (D).

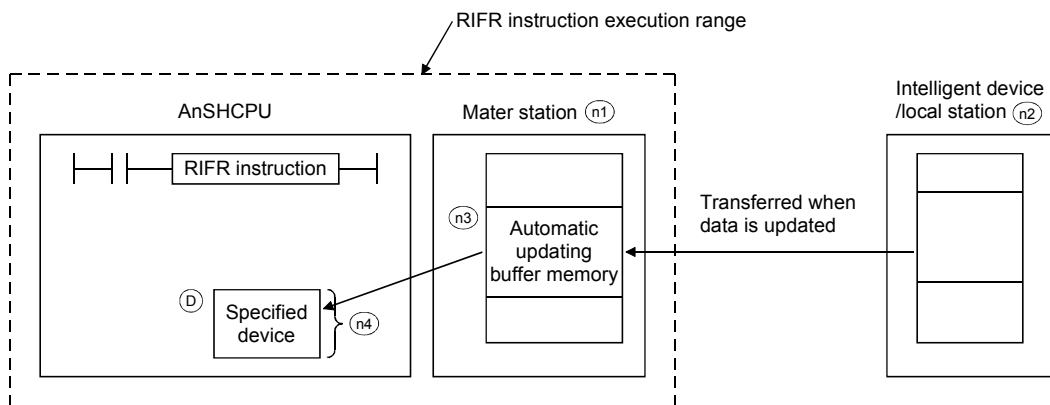

- (2) When executed, the RIFR instruction reads data from the automatic updating buffer of the master module.
- (3) Up to 8192 points may be read by the RIFR instruction.
- (4) To set the number of automatic updating buffer memory points, make the automatic updating buffer size setting using the network parameter instruction (RLPA instruction).

Execution Conditions

As shown below, when the LEDA instruction is used, the RIFR instruction is executed every scan while the read command is ON. When the LEDB instruction is used, the RIFR instruction is executed only one scan on the leading edge (OFF → ON) of the read command.

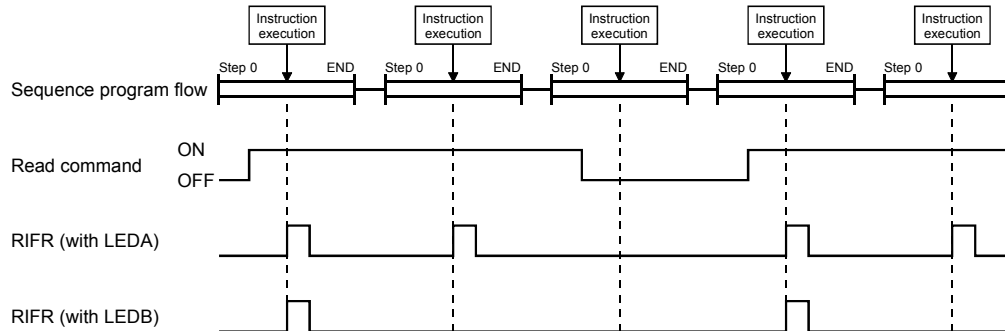

Operation Errors

Either of the following conditions will result in an operation error and the error flag (M9011) switch on.

Description	Error Code	
	D9008	D9092
The buffer address specified is outside the range of automatic updating buffer memory designation range.	50	503
The number of refresh points is greater than 8192.		

Program Examples

The following program reads 11 points of data to D100 and thereafter from 400_H of the automatic updating buffer memory set to station number 1 in the master module of CC-Link allocated to I/O numbers 000 to 01F.

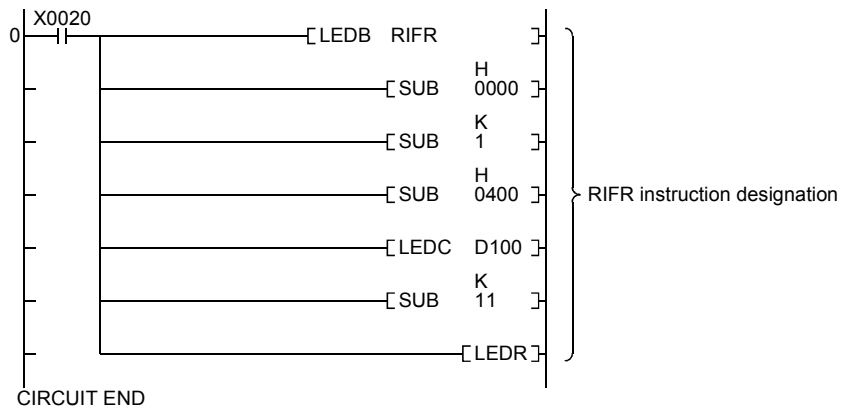

3.5 Write to Automatic Updating Buffer Memory RITO

	Available Devices																Digit designation	Number of steps	Subset	Index	Carry flag	Error flag			
	Bit Device							Word Device						Constant		Pointer							Level		
	X	Y	M	L	S	B	F	T	C	D	W	R	A0	A1	Z	V							K	H	P
(n1)																	O	O							
(n2)								O	O	O	O	O					O	O							
(n3)								O	O	O	O	O					O	O							
(D)								O	O	O	O	O													
(n4)								O	O	O	O	O					O	O							

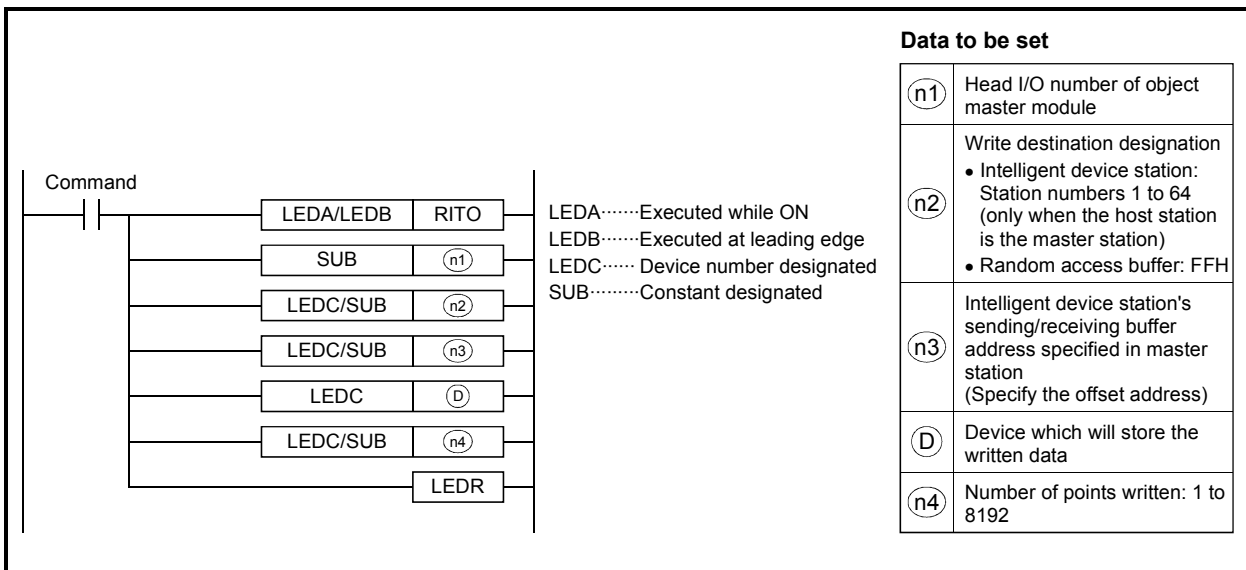

Functions

- (1) Writes the points of data specified at (n4) from the devices beginning with the one specified at (D) to the automatic updating buffer memory addresses beginning with the specified one at (n3) for the station having the station number specified at (n2) in the master module specified at (n1).

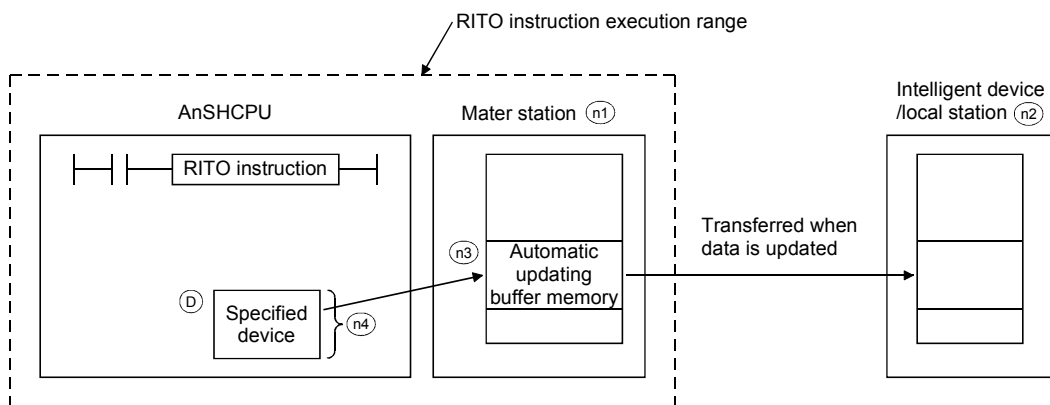

- (2) When executed, the RITO instruction writes data.
- (3) Up to 8192 points may be written by the RITO instruction.
- (4) To set the number of automatic updating buffer memory points, make the automatic updating buffer size setting using the network parameter instruction (RLPA instruction).

Execution Conditions

As shown below, when the LEDA instruction is used, the RITO instruction is executed every scan while the write command is ON. When the LEDB instruction is used, the RITO instruction is executed only one scan on the leading edge (OFF → ON) of the write command.

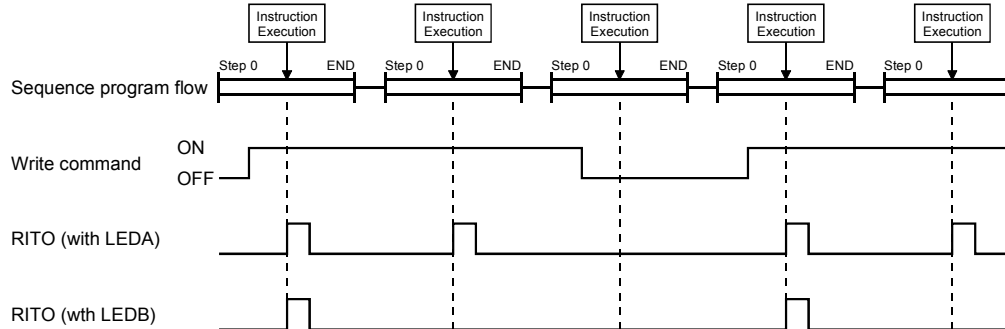

Operation Errors

Either of the following conditions will result in an operation error and the error flag (M9011) switch on.

Description	Error Code	
	D9008	D9092
The buffer address specified is outside the range of automatic updating buffer memory designation range.	50	503
The number of refresh points is greater than 8192.		

Program Examples

The following program writes "ABCDEFGHIJ" to 200H and subsequent addresses of the automatic updating buffer memory for the station set to station number 1 in the master module of CC-Link allocated to I/O numbers 000 to 01F.

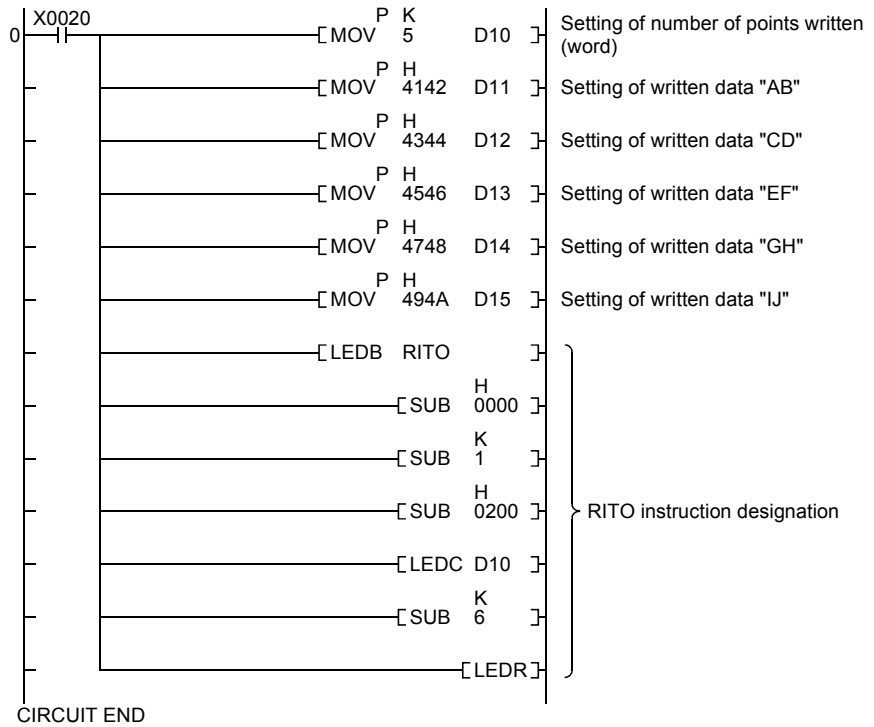

3.6 Read from Remote Station Buffer Memory RIRD

	Available Devices																Digit designation	Number of steps	Subset	Index	Carry flag	Error flag						
	Bit Device							Word Device							Constant	Pointer							Level					
	X	Y	M	L	S	B	F	T	C	D	W	R	A0	A1										Z	V	K	H	P
(n1)																	○	○										
(n2)																	○	○										
(D1)								○	○	○	○	○												26				
(D2)		○	○	○	○	○																						○

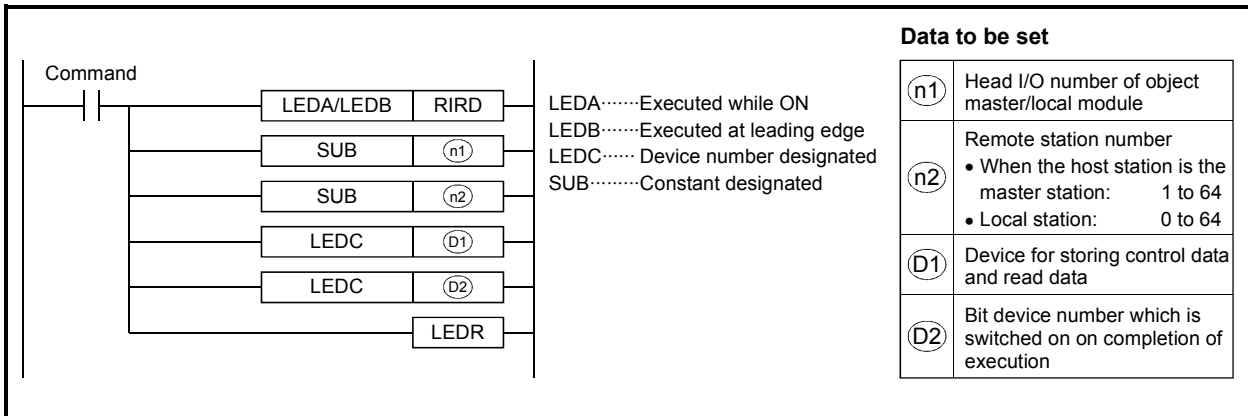

Control Data

(1) Control data setting items

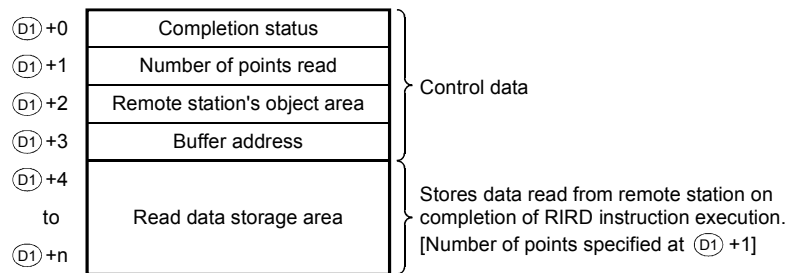

(2) Number of control data area points

Data read from a remote station is stored into the area after the 4 points of control data [(D1)_□+0 to (D1)_□+3].
 Reserve the control data area for 4 points + [number of points specified at (D1)_□+1] successively.

REMARKS

1) A remote station is a generic term for an intelligent device station and a local station.

(3) Control data

Item	Set Data	Setting Range	Setting End
Completion status	Status on completion of instruction execution is stored. 0 : No error Other than 0 : Error code *1	—	System
Number of points read	Specify the number of data read (word basis).	1 to 480 *2	User
Remote station's object area	<ul style="list-style-type: none"> Set "0004H" when accessing the buffer memory of an intelligent device station. Set "2004H" when accessing the random access buffer memory of a local station. 	0004H 2004H	User
Buffer memory address	Specify the head address of the buffer memory.	*3	User
Read data	—	—	System

REMARKS

- 1) *1: For error codes at error occurrence, refer to the following manual.
Control & Communication-Link System Master · Local Module type AJ65BT11/A1SJ61BT11 User's Manual
- 2) *2: Indicates the maximum number of data read.
Set a value within the remote station buffer memory capacity and parameter-set receiving buffer area setting range.
- 3) *3: Refer to the manual of the remote station from which data is read.
When specifying the random access buffer memory, set the address with the head of the random access buffer memory defined as 0.

Functions

- (1) Reads the points of data specified at $(D1) + 1$ from the buffer memory address specified at $[(D1) + 3]$ in the remote station having the station number specified at $(n2)$ and connected to the master/local module specified at $(n1)$, and stores that data into the devices starting from the one specified at $(D1) + 4$.
On completion of reading, the bit device specified at $(D2)$ switches on only one scan.
On abnormal completion, the bit device at $(D2) + 1$ switches on only one scan.

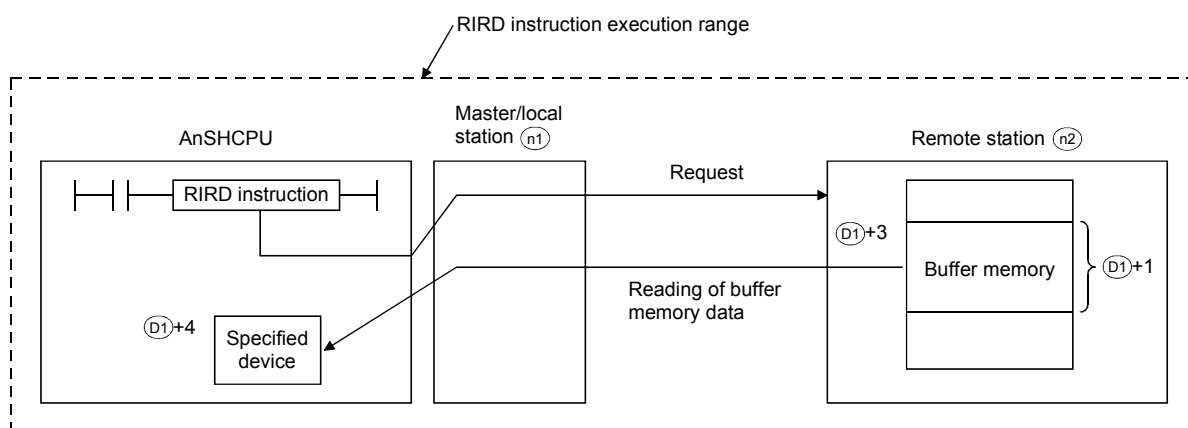

- (2) The RIRD instruction may be executed for two or more remote stations at the same time.
However, this instruction cannot be executed for the same remote station in two or more locations at the same time.

- (3) Before executing the RIRD instruction, set the network parameters using the RLPA instruction (network parameter setting).
If the RIRD instruction is executed without the network parameters set, abnormal completion will occur and "4B00H" be stored into the completion status.
- (4) No processing will be performed if the number of read points specified at (D1) +1 is "0".

Execution Conditions

When the LEDA instruction is used, the RIRD instruction is executed every scan while the read command is ON. When the LEDB instruction is used, the RIRD instruction is executed only one scan on the leading edge (OFF → ON) of the read command.

Note that several scans will be required until the completion of read processing by the RIRD instruction. Therefore, execute the next RIRD instruction after the completion device has switched on.

(The RIRD instruction executed before the completion of RIRD instruction execution is ignored.)

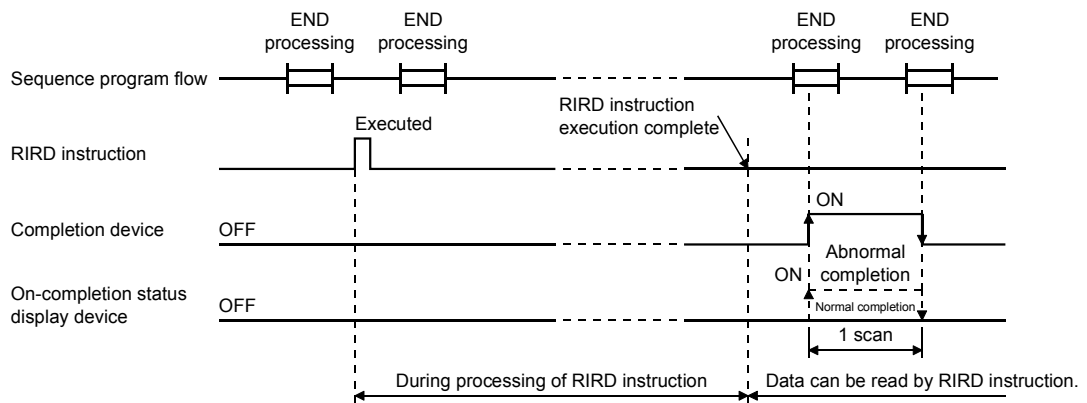

Operation Error

The following condition will result in an operation error and the error flag (M9011) switch on.

Description	Error Code	
	D9008	D9092
The number of read points specified at (D1) +1 is outside the range 0 to 480.	50	503

Program Example

The following program reads 1 point of data from 1A8_H of the buffer memory of the intelligent device station having station number 1 and connected to the master module of CC-Link allocated to I/O numbers 000 to 01F.

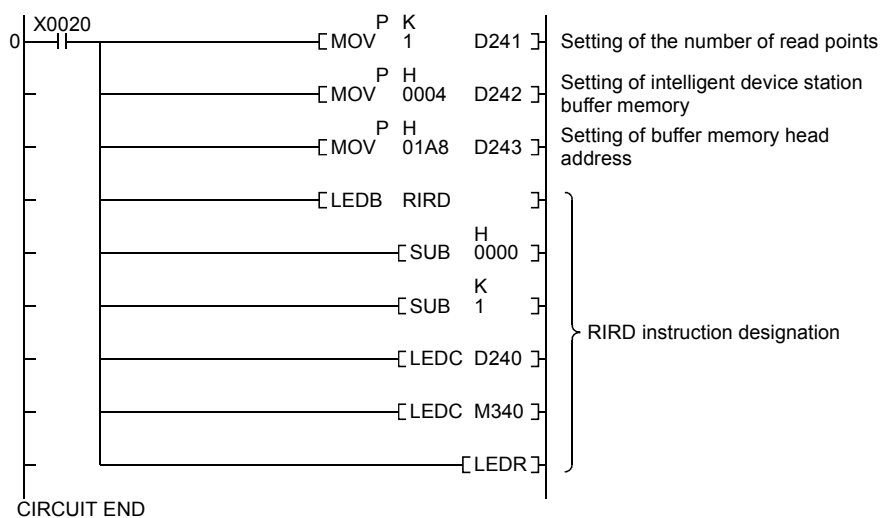

3.7 Write to Remote Station Buffer Memory RIWT

	Available Devices																Digit designation	Number of steps	Subset	Index	Carry flag	Error flag			
	Bit Device							Word Device							Constant								Pointer		Level
	X	Y	M	L	S	B	F	T	C	D	W	R	A0	A1	Z	V							K	H	P
(n1)																	○	○							
(n2)																	○	○							
(D1)								○	○	○	○	○											○		
(D2)		○	○	○	○	○																			

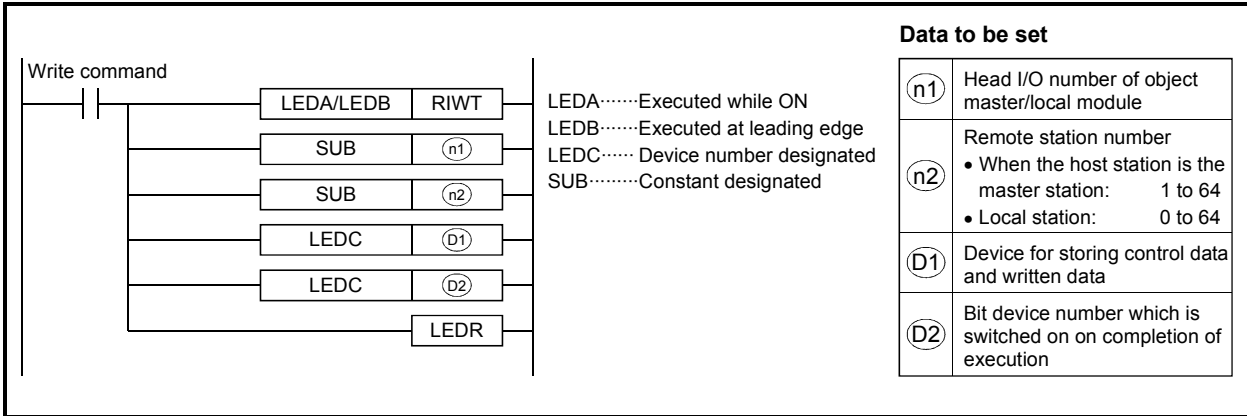

Control Data

(1) Control data setting items

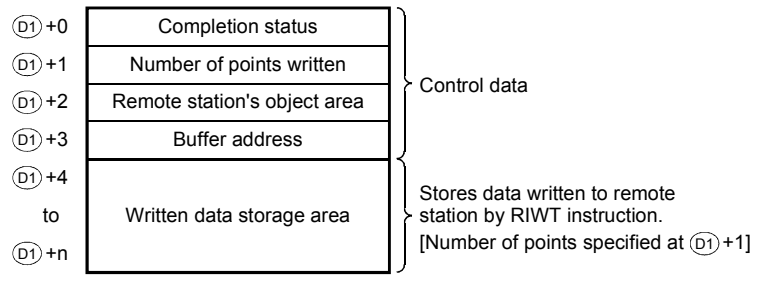

(2) Control data

Item	Set Data	Setting Range	Setting End
Completion status	Status on completion of instruction execution is stored. 0 : No error Other than 0 : Error code *1	—	System
Number of points written	Specify the number of data written (word basis).	1 to 480 *2	User
Remote station's object area	<ul style="list-style-type: none"> Set "0004H" when accessing the buffer memory of an intelligent device station. Set "2004H" when accessing the random access buffer memory of a local station. 	0004H 2004H	User
Buffer memory address	Specify the head address of the buffer memory.	*3	User
Written data	—	—	User

REMARKS

- 1) *1: For error codes at error occurrence, refer to the following manual.
Control & Communication-Link System Master · Local Module type AJ65BT11/A1SJ61BT11 User's Manual
- 2) *2: Indicates the maximum number of data written.
Set a value within the remote station buffer memory capacity and parameter-set receiving buffer area setting range.
- 3) *3: Refer to the manual of the remote station to which data is written.
When specifying the random access buffer memory, set the address with the head of the random access buffer memory defined as 0.

Functions

- (1) Writes the points of data specified at (D1) +1 from the devices beginning with the one specified at (D1) +4 to the buffer memory address specified at [(D1) +3] in the remote station having the station number specified at (n2) and connected to the master/local module specified at (n1), and stores that data into.
On completion of writing, the bit device specified at (D2) switches on only one scan.
On abnormal completion, the bit device at (D2) +1 switches on only one scan.

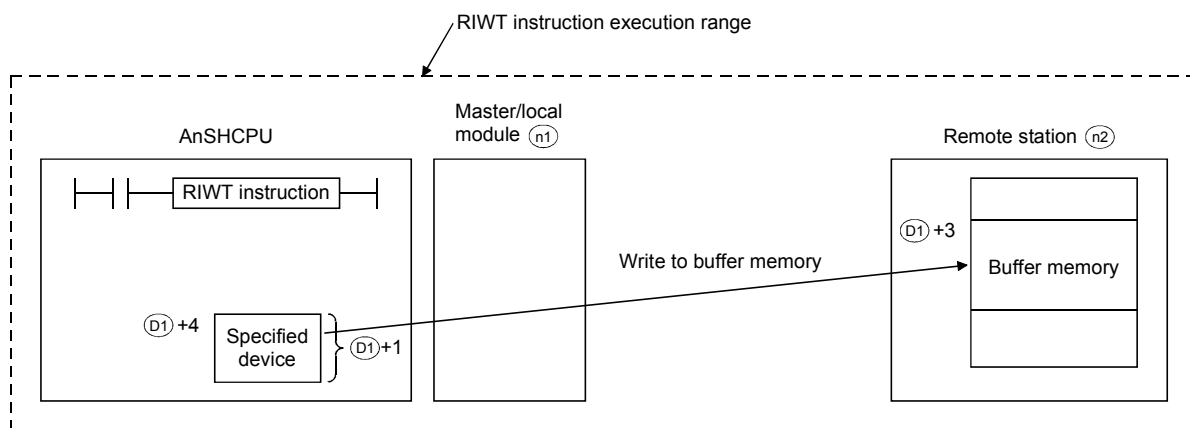

- (2) The RIWT instruction may be executed for two or more remote stations at the same time.
However, this instruction cannot be executed for the same remote station in two or more locations at the same time.

- (3) Before executing the RIWT instruction, set the network parameters using the RLPA instruction (network parameter setting).
If the RIWT instruction is executed without the network parameters set, abnormal completion will occur and "4B00H" be stored into the completion status.
- (4) No processing will be performed if the number of written points specified at (D1) +1 is "0".

Execution Conditions

When the LEDA instruction is used, the RIWT instruction is executed every scan while the write command is ON. When the LEDB instruction is used, the RIWT instruction is executed only one scan on the leading edge (OFF → ON) of the write command.

Note that several scans will be required until the completion of write processing by the RIWT instruction. Therefore, execute the next RIWT instruction after the completion device has switched on.

(The RIWT instruction executed before the completion of RIWT instruction execution is ignored.)

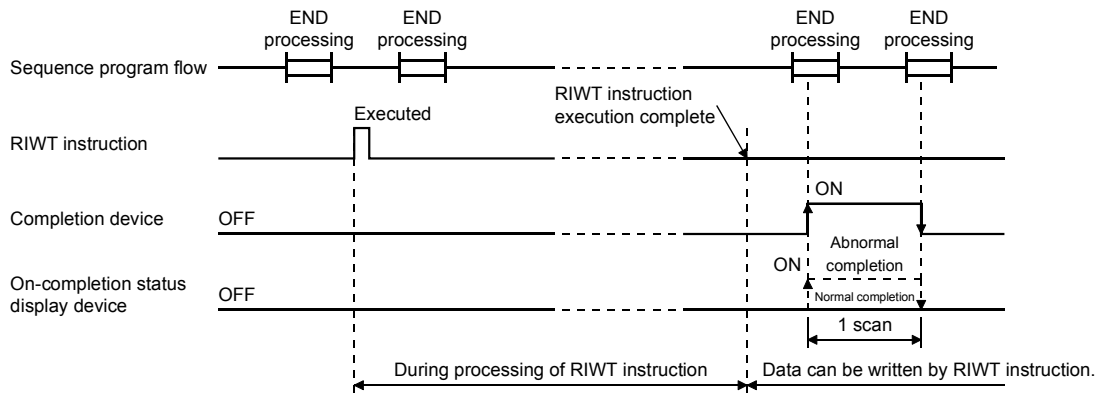

Operation Error

The following condition will result in an operation error and the error flag (M9011) switch on.

Description	Error Code	
	D9008	D9092
The number of written points specified at (D1) +1 is outside the range 0 to 480.	50	503

Program Example

The following program writes data 10 and 20 to 111_H and 112_H of the buffer memory of the intelligent device station having station number 1 and connected to the master module of CC-Link allocated to I/O numbers 000 to 01F.

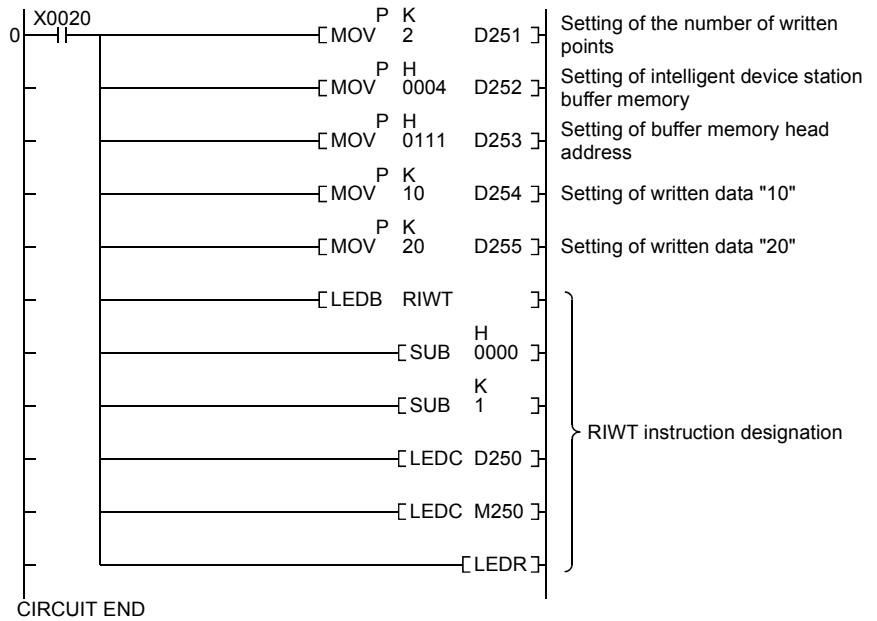

3.8 Read from Intelligent Device Station Buffer Memory (with Handshake) RIRCV

	Available Devices																Digit designation	Number of steps	Subset	Index	Carry flag	Error flag			
	Bit Device							Word Device							Constant								Pointer		Level
	X	Y	M	L	S	B	F	T	C	D	W	R	A0	A1	Z	V							K	H	P
(n1)																	○	○							
(n2)																	○	○							
(D1)								○	○	○	○	○												○	
(D2)								○	○	○	○	○													
(D3)		○	○	○	○	○																			

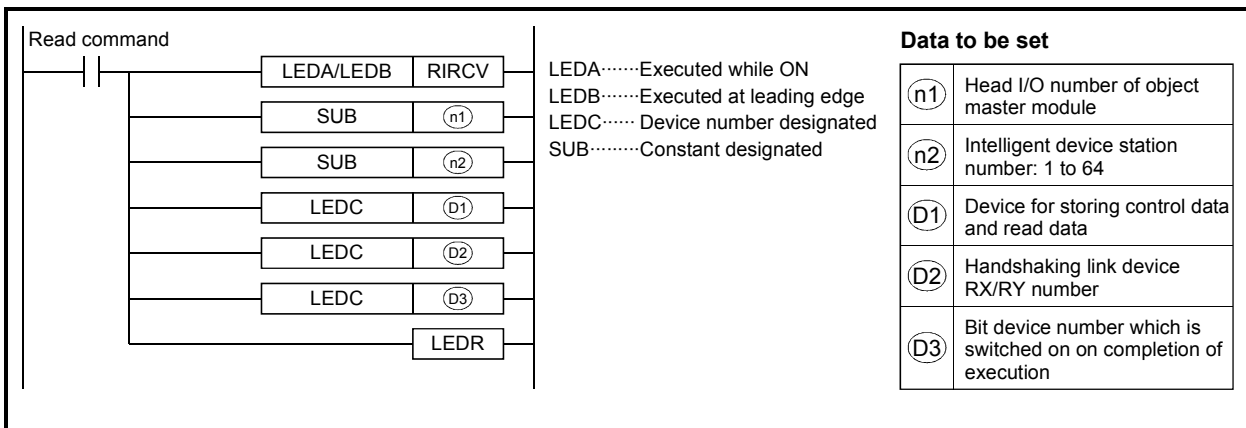

Control Data

(1) Control data setting items

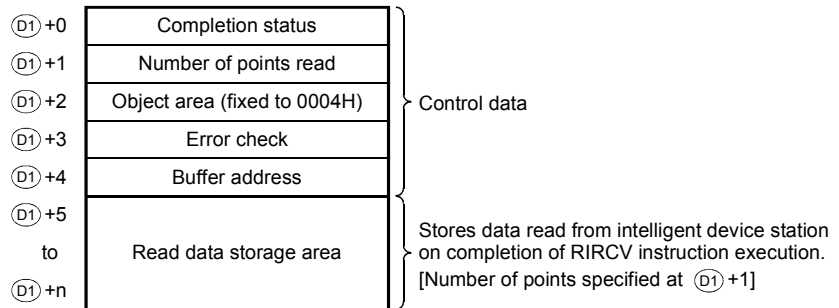

(2) Number of control data area points

Data read from an intelligent device station is stored into the area after the 5 points of control data [(D1)+0 to (D1)+4]. Reserve the control data area for 5 points + [number of points specified at (D1)+1] successively.

(3) Control data

Item	Set Data	Setting Range	Setting End
Completion status	Status on completion of instruction execution is stored. 0 : No error Other than 0 : Error code *1	—	System
Number of points read	Specify the number of data read (word basis).	1 to 480 *2	User
Object area	Set "0004H" when accessing the buffer memory of an intelligent device station.	0004H	User
Error check	Specify the error check device. 0 : Completion status is used for error check. Other than 0 : RX+1 is used for error check.	0, 1	User
Buffer memory address	Specify the head address of the buffer memory.	*3	User
Read data	—	—	System

REMARKS

- 1) *1: For error codes at error occurrence, refer to the following manual.
Control & Communication-Link System Master · Local Module type AJ65BT11/A1SJ61BT11 User's Manual
- 2) *2: Indicates the maximum number of data read.
Set a value within the intelligent device station buffer memory capacity and parameter-set receiving buffer area setting range.
- 3) *3: Refer to the manual of the intelligent device station from which data is read.

Handshaking Link Devices

(1) Handshaking link device setting items

(D2)+0	RX	RY
(D2)+1	RWr	

(2) Setting of handshaking link devices

Item	Set Data	Setting Range	Setting End
RX	Specify the handshaking RX number of the intelligent device station.	0 to 127	User *2
RY	Specify the handshaking RY number of the intelligent device station.	0 to 127	User *2
RWr	Specify the handshaking RWr number of the intelligent device station.	0 to 15 FF *1	User *2

POINTS

- (1) *1: When FF_H is set, no number is specified.
- (2) *2: The RX, RY and RW numbers used are set by the user. Note that RX and RY ON/OFF control and RW data setting are performed by the system and cannot be changed by the user. If RX, RY and RW are changed by the user, the RIRVC instruction will not be completed properly.

Functions

- (1) Reads the points of data specified at $(D1) + 1$ from the buffer memory address specified at $[(D1) + 3]$ in the intelligent device station having the station number specified at $(n2)$ and connected to the master module specified at $(n1)$, and stores that data into the devices starting from the one specified at $(D1) + 4$.
 On completion of reading, the bit device specified at $(D2)$ switches on only one scan.
 On abnormal completion, the bit device at $(D2) + 1$ switches on only one scan.

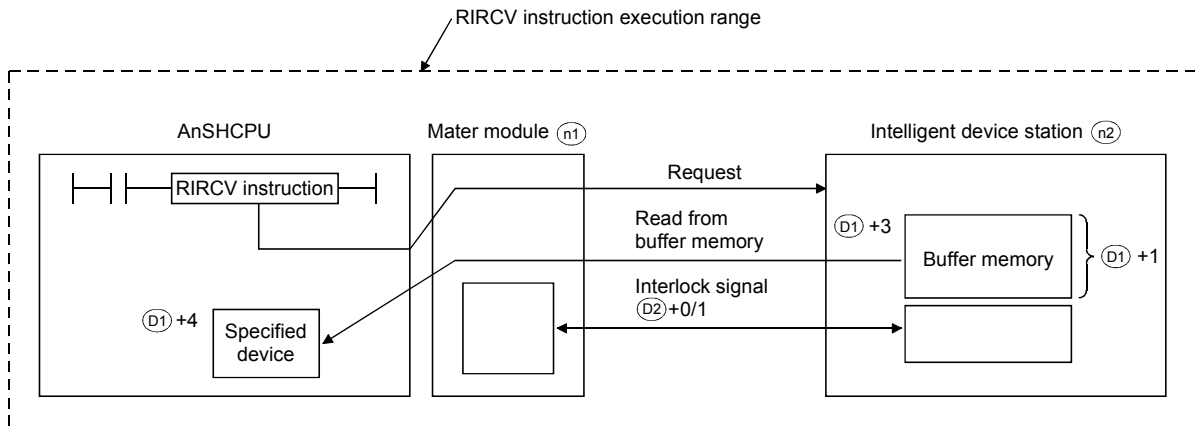

- (2) The RIRCV instruction may be executed for two or more intelligent device stations at the same time.
 However, this instruction cannot be executed for the same intelligent device station in two or more locations at the same time.
- (3) Before executing the RIRCV instruction, set the network parameters using the RLPA instruction (network parameter setting).
 If the RIRCV instruction is executed without the network parameters set, abnormal completion will occur and "4B00H" be stored into the completion status.
- (4) No processing will be performed if the number of read points specified at $(D1) + 1$ is "0".

Execution Conditions

When the LEDA instruction is used, the RIRCV instruction is executed every scan while the read command is ON. When the LEDB instruction is used, the RIRCV instruction is executed only one scan on the leading edge (OFF → ON) of the read command.
 Note that several scans will be required until the completion of read processing by the RIRCV instruction. Therefore, execute the next RIRCV instruction after the completion device has switched on.
 (The RIRCV instruction executed before the completion of RIRCV instruction execution is ignored.)

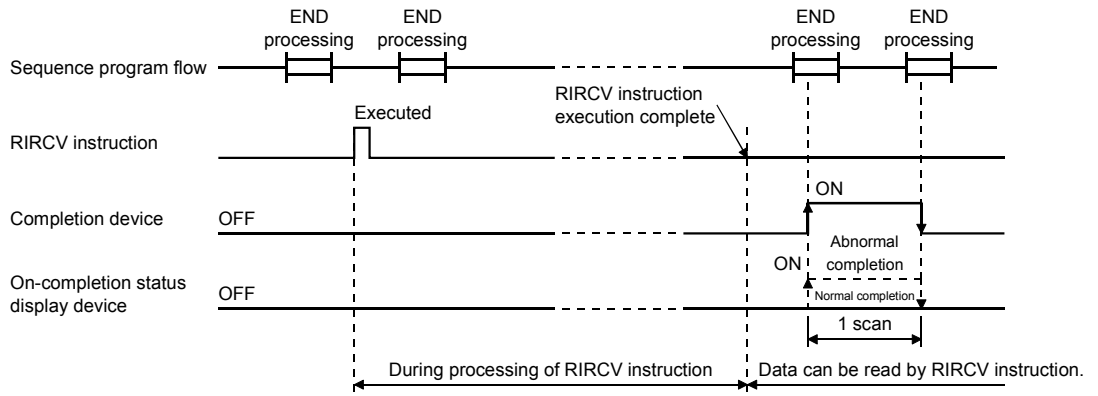

Operation Error

The following condition will result in an operation error and the error flag (M9011) switch on.

Description	Error Code	
	D9008	D9092
The number of read points specified at (D1) +1 is outside the range 0 to 480.	50	503

Program Example

The following program reads data from 400_H-405_H of the buffer memory of the intelligent device station having station number 1 and connected to the master module of CC-Link allocated to I/O numbers 000 to 01F. The completion status is used for error check. Also RX2, RY2 and RWR2 are used as handshaking link devices.

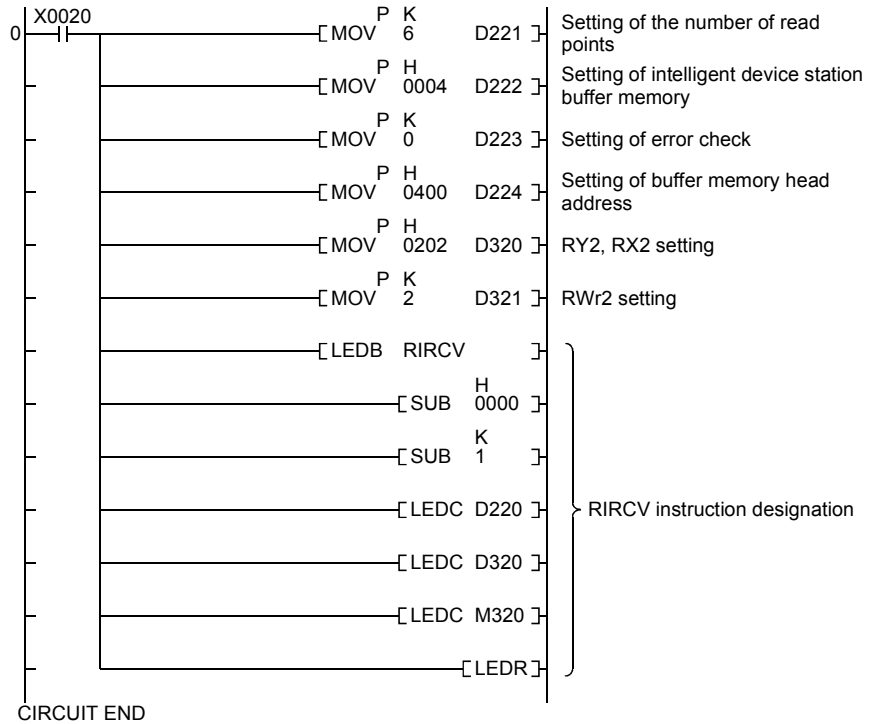

3.9 Write to Intelligent Device Station Buffer Memory (with Handshake) RISEND

	Available Devices																	Digit designation	Number of steps	Subset	Index	Carry flag	Error flag			
	Bit Device							Word Device							Constant		Pointer							Level		
	X	Y	M	L	S	B	F	T	C	D	W	R	A0	A1	Z	V	K							H	P	I
(n1)																	○	○								
(n2)																	○	○								
(D1)									○	○	○	○	○													○
(D2)									○	○	○	○	○													
(D3)		○	○	○	○	○																				

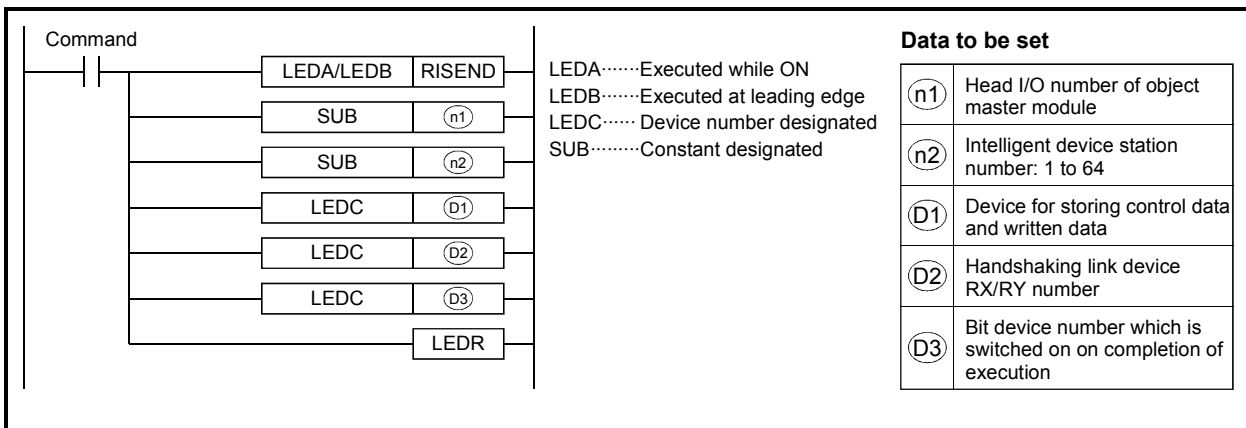

Control Data

(1) Control data setting items

(D1) +0	Completion status	} Control data
(D1) +1	Number of points written	
(D1) +2	Fixed to 0004H	
(D1) +3	Error check	
(D1) +4	Buffer address	
(D1) +5 to (D1) +n	Written data storage area	} Stores data written to intelligent device station by RISEND instruction. [Number of points specified at (D1) +1]

(2) Control data

Item	Set Data	Setting Range	Setting End
Completion status	Status on completion of instruction execution is stored. 0 : No error Other than 0 : Error code *1	—	System
Number of points written	Specify the number of data written (word basis).	1 to 480 *2	User
Object area	Set "0004H" when accessing the buffer memory of an intelligent device station.	0004H	User
Error check	Specify the error check device. 0 : Completion status is used for error check. Other than 0 : RX+1 is used for error check.	0,1	User
Buffer memory address	Specify the head address of the buffer memory.	*3	User
Written data storage area	—	—	User

REMARKS

- 1) *1: For error codes at error occurrence, refer to the following manual.
Control & Communication-Link System Master · Local Module type AJ65BT11/A1SJ61BT11 User's manual
- 2) *2: Indicates the maximum number of data written.
Set a value within the intelligent device station buffer memory capacity and parameter-set receiving buffer area setting range.
- 3) *3: Refer to the manual of the intelligent device station to which data is written.

Handshaking Link Devices

(1) Handshaking link device setting items

(D2)+0	RX	RY
(D2)+1	RWr	

(2) Setting of handshaking link devices

Item	Set Data	Setting Range	Setting End
RX	Specify the handshaking RX number of the intelligent device station.	0 to 127	User ^{~2}
RY	Specify the handshaking RY number of the intelligent device station.	0 to 127	User ^{~2}
RWr	Specify the handshaking RWr number of the intelligent device station.	0 to 15 FF *1	User ^{~2}

POINTS

- (1) *1: When FF_H is set, no number is specified.
- (2) *2: The RX, RY and RW numbers used are set by the user.
Note that RX and RY ON/OFF control and RWr data setting are performed by the system and cannot be changed by the user.
If RX, RY and RW are changed by the user, the RISEND instruction will not be completed properly.

Functions

- (1) Writes the points of data specified at $(D1) + 1$ from the devices beginning with the one specified at $(D1) + 5$ to the buffer memory address specified at $[(D1) + 4]$ in the intelligent device station having the station number specified at $(n2)$ and connected to the master module specified at $(n1)$.
 On completion of writing, the bit device specified at $(D3)$ switches on only one scan.
 On abnormal completion, the bit device at $(D2) + 1$ switches on only one scan.

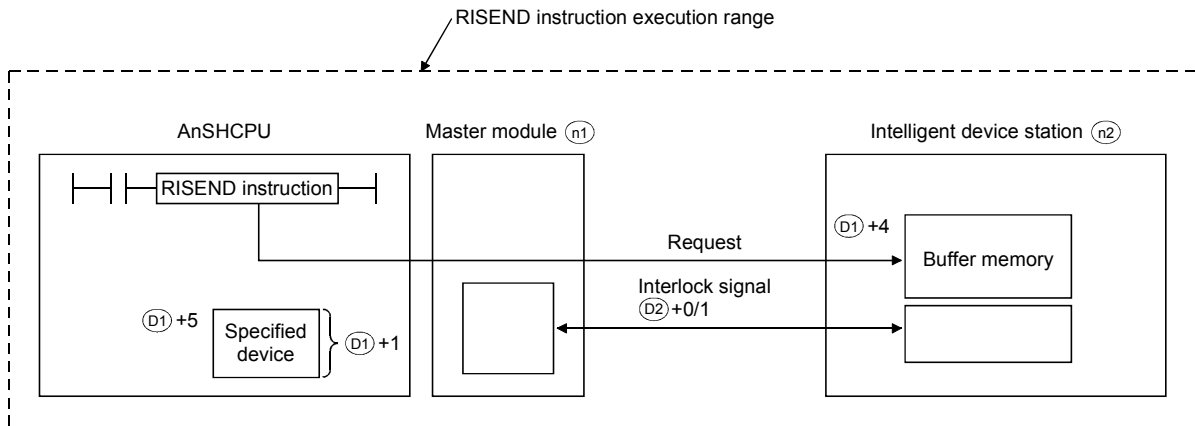

- (2) The RISEND instruction may be executed for two or more intelligent device stations at the same time. However, this instruction cannot be executed for the same intelligent device station in two or more locations at the same time.
- (3) Before executing the RISEND instruction, set the network parameters using the RLPA instruction (network parameter setting). If the RISEND instruction is executed without the network parameters set, abnormal completion will occur and "4B00H" be stored into the completion status.
- (4) No processing will be performed if the number of written points specified at $(D1) + 1$ is "0".

Execution Conditions

When the LEDA instruction is used, the RISEND instruction is executed every scan while the write command is ON. When the LEDB instruction is used, the RISEND instruction is executed only one scan on the leading edge (OFF → ON) of the write command. Note that several scans will be required until the completion of write processing by the RISEND instruction. Therefore, execute the next RISEND instruction after the completion device has switched on. (The RISEND instruction executed before the completion of RISEND instruction execution is ignored.)

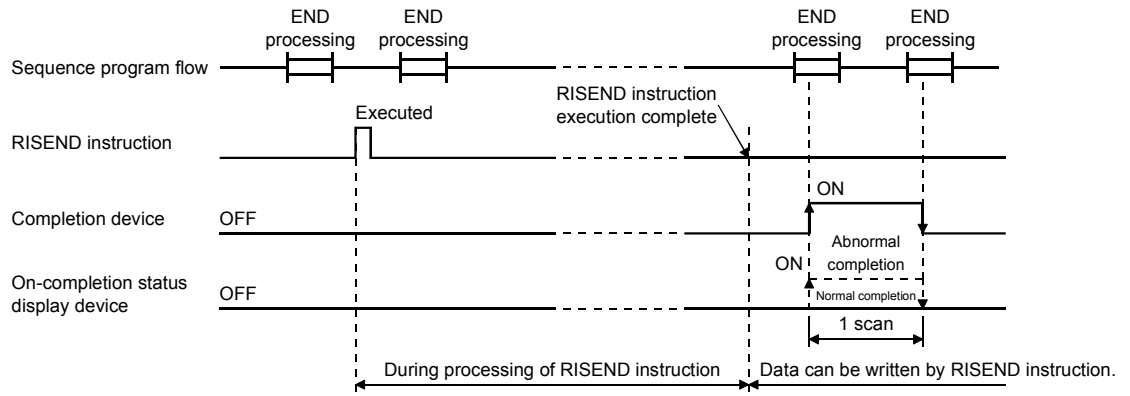

Operation Error

The following condition will result in an operation error and the error flag (M9011) switch on.

Description	Error Code	
	D9008	D9092
The number of written points specified at (D1) +1 is outside the range 0 to 480.	50	503

Program Example

The following program writes the number of data written and data "ABCDEFGH IJ" to 200_H-205_H of the buffer memory of the intelligent device station having station number 1 and connected to the master module of CC-Link allocated to I/O numbers 000 to 01F.

The completion status is used for error check.

Also RX0, RY0 and RWR0 are used as handshaking link devices.

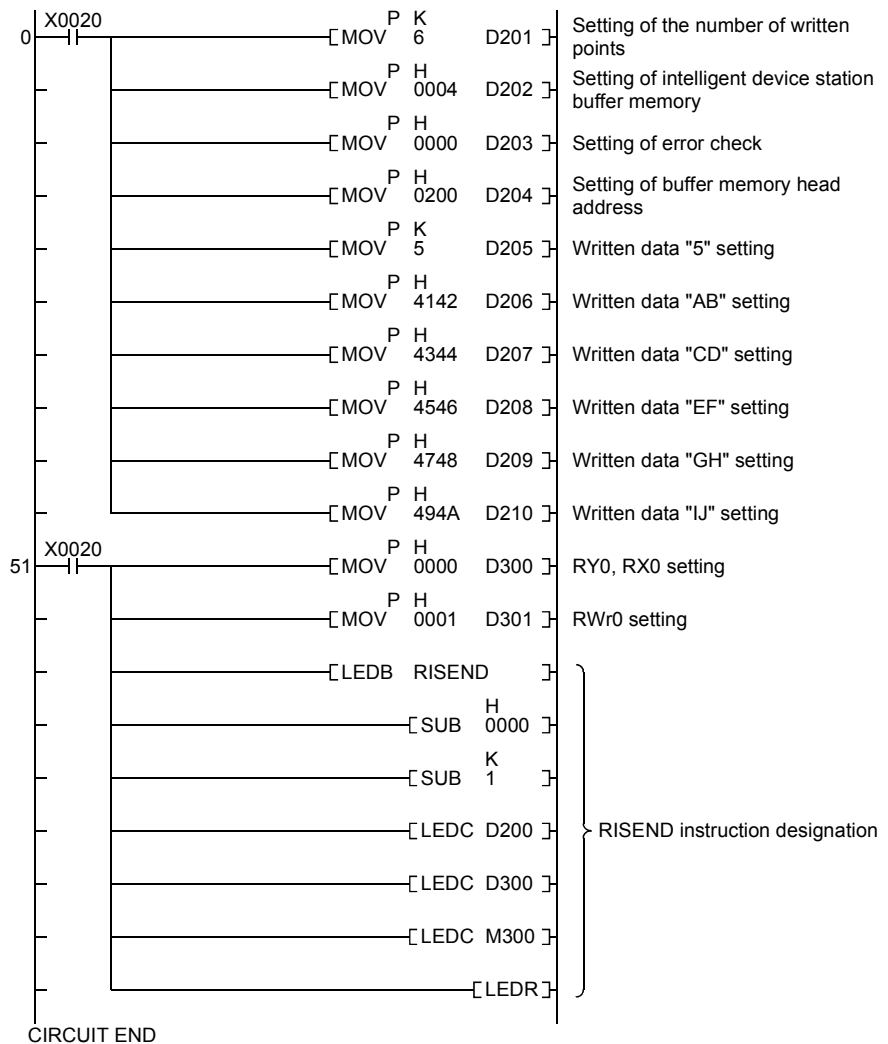

3.10 Read from Remote Device Station RDGET

	Available Devices																Digit designation	Number of steps	Subset	Index	Carry flag	Error flag								
	Bit Device							Word Device							Constant								Pointer		Level					
	X	Y	M	L	S	B	F	T	C	D	W	R	A0	A1	Z	V							K	H	P	I	N			
(n1)																	O	O												
(n2)																	O	O												
(D1)								O	O	O	O	O																		
(D2)								O	O	O	O	O																		

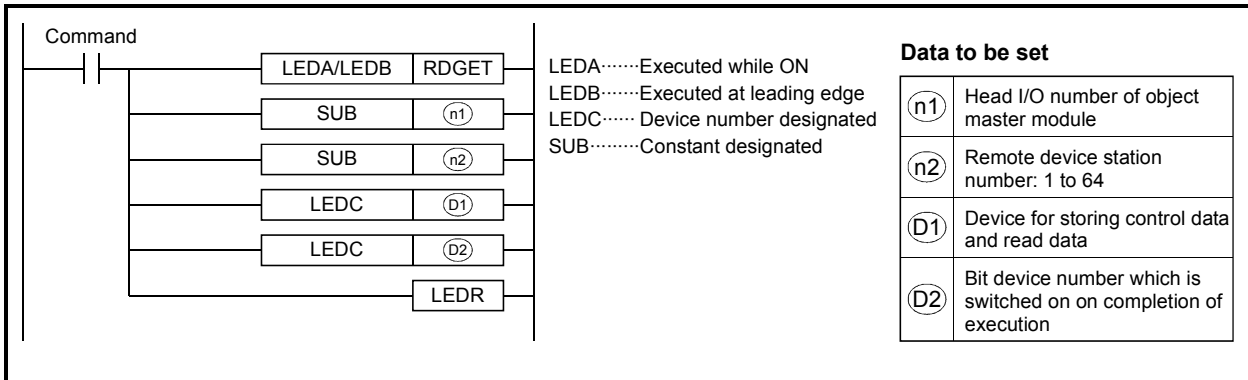

Control Data

(1) Control data setting items

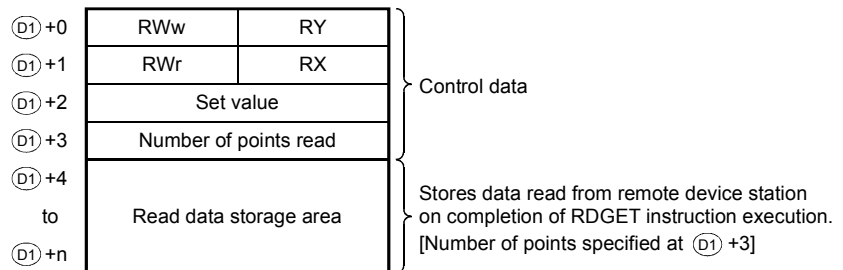

(2) Number of control data area points

Data read from a remote device station is stored into the area after the 4 points of control data [(D1) +0 to (D1) +3]. Reserve the control data area for 4 points + [number of points specified at (D1) +3] successively.

(3) Control data settings

Item	Set Data	Setting Range	Setting End
RY	Read request	0 to 127	User ^{*2}
RWw	Read request	0 to 15	User ^{*2}
RX	Read completion	0 to 127	User ^{*2}
RWr	Read completion	0 to 15	User ^{*2}
Set value	Specify the reading set value allocated to the remote device station	*1	User
Number of points read	Specify the number of data read (word basis).	1 to 16	User

POINTS

- (1) *1: Refer to the manual of the remote device station from which data is read.
- (2) *2: The RY, RWw, RX and RWr numbers used are set by the user.
Note that RY and RX ON/OFF control and RWw and RWr data setting are performed by the system. The user cannot perform RY and RX ON/OFF control and RWw and RWr data setting.

Functions

- (1) Reads the points of data specified at (D1) +3 from the link registers in the remote device station having the station number specified at (n2) and connected to the master module specified at (n1), and stores that data into the devices starting from the one specified at (D1) +4. On completion of reading, the bit device specified at (D2) switches on only one scan. On abnormal completion, the bit device at (D2) +1 switches on only one scan.

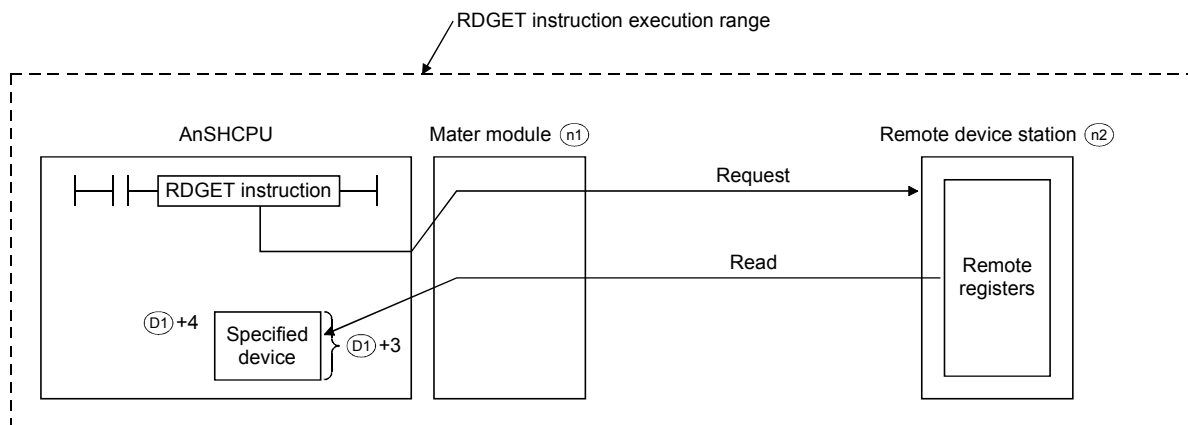

- (2) The RDGET instruction may be executed for two or more intelligent device stations at the same time. However, this instruction cannot be executed for the same intelligent device station in two or more locations at the same time.
- (3) As control data, specify the values given in the manual of the remote device station. If wrong setting is made, the instruction will not be completed.

Execution Conditions

When the LEDA instruction is used, the RDGET instruction is executed every scan while the read command is ON. When the LEDB instruction is used, the RDGET instruction is executed only one scan on the leading edge (OFF → ON) of the read command.

Note that several scans will be required until the completion of read processing by the RDGET instruction. Therefore, execute the next RDGET instruction after the completion device has switched on.

(The RDGET instruction executed before the completion of RDGET instruction execution is ignored.)

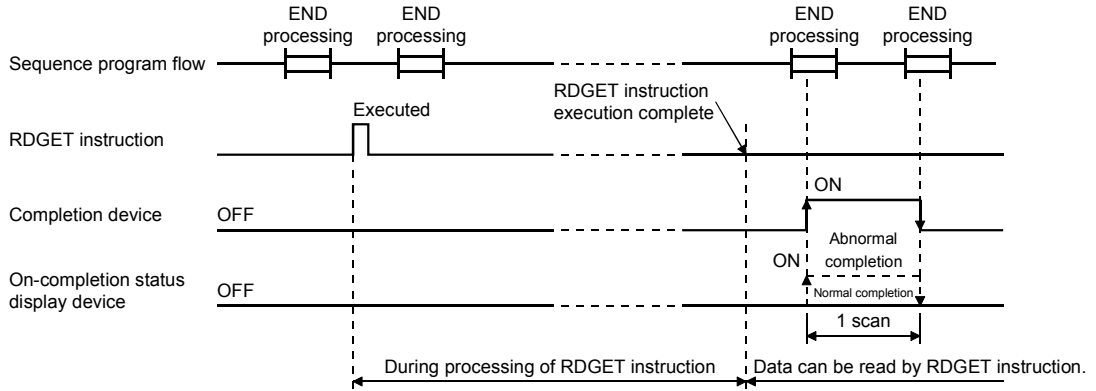

Operation Error

The following condition will result in an operation error and the error flag (M9011) switch on.

Description	Error Code	
	D9008	D9092
The number of read points specified at (D1) +3 is outside the range 0 to 480.	50	503

Program Example

The following program reads 1 point of data from the remote device station having station number 1 and connected to the master module of CC-Link allocated to I/O numbers 000 to 01F.

This program assumes that control data are stored in D1000-D1003.

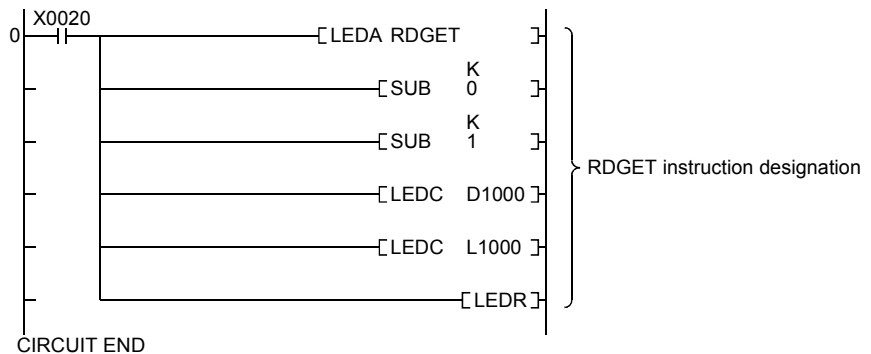

3.11 Write to Remote Device Station RDPUT

	Available Devices																	Digit designation	Number of steps	Subset	Index	Carry flag	Error flag		
	Bit Device							Word Device							Constant		Pointer							Level	
	X	Y	M	L	S	B	F	T	C	D	W	R	A0	A1	Z	V	K							H	P
(n1)																	O	O							
(n2)																	O	O							
(D1)								O	O	O	O	O													O
(D2)		O	O	O	O	O																			

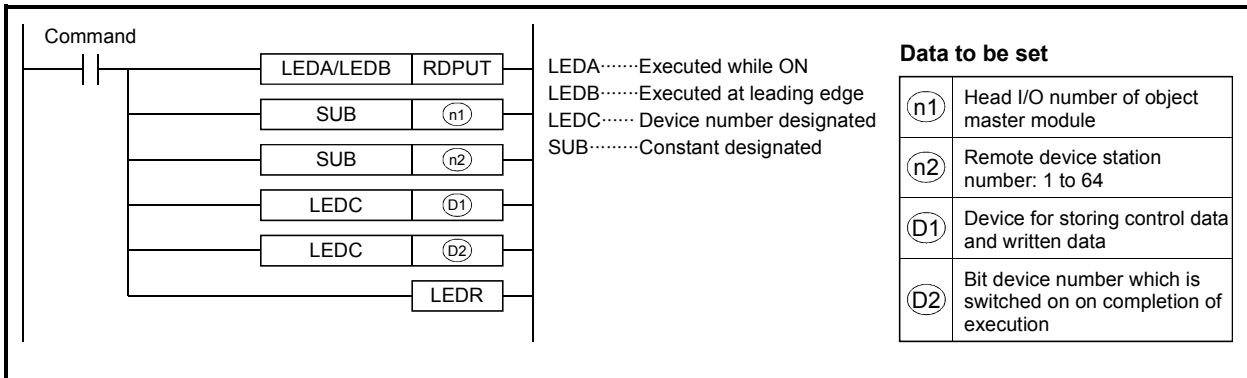

Control Data

(1) Control data setting items

(D1)+0	RWw1	RY	} Control data
(D1)+1	RWr2	RX	
(D1)+2	Set value		
(D1)+3	Number of points written		
(D1)+4	Written data storage area		
(D1)+n			Stores data written to remote device station on completion of RDPUT instruction execution. [Number of points specified at (D1) +3]

(2) Control data settings

Item	Set Data	Setting Range	Setting End
RY	Write request	0 to 127	User ^{*2}
RWw	Write request	0 to 15	User ^{*2}
RX	Write completion	0 to 127	User ^{*2}
RWr	Write completion	0 to 15	User ^{*2}
Set value	Specify the writing set value allocated to the remote device station	*1	User
Number of points written	Specify the number of data written (word basis).	1 to 16	User

POINTS

- (1) *1: Refer to the manual of the remote device station to which data is written.
- (2) *2: The RY, RWw, RX and RWr numbers used are set by the user.
Note that RY and RX ON/OFF control and RWw and RWr data setting are performed by the system. The user cannot perform RY and RX ON/OFF control and RWw and RWr data setting.

Functions

- (1) Writes the points of data specified at (D1) +3 stored from the devices beginning with the one specified at (D1) +4 using RX and RY specified at (D1) +0-1 to the link registers in the remote device station having the station number specified at (n2) and connected to the master module specified at (n1).
 On completion of writing, the bit device specified at (D2) switches on only one scan.
 On abnormal completion, the bit device at (D2) +1 switches on only one scan.

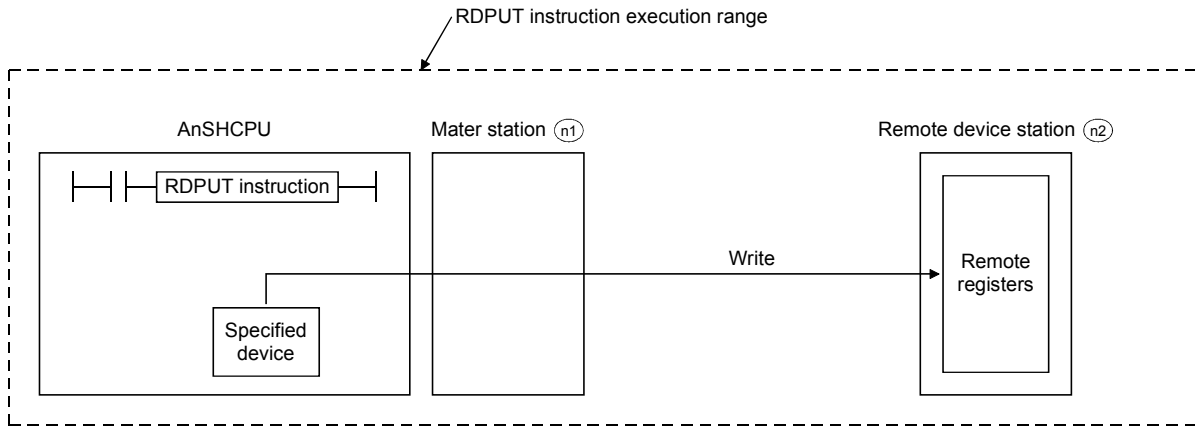

- (2) The RDPUT instruction may be executed for two or more remote device stations at the same time.
 However, this instruction cannot be executed for the same remote device station in two or more locations at the same time.
- (3) As control data, specify the values given in the manual of the remote device station.
 If wrong setting is made, the instruction will not be completed.

Execution Conditions

When the LEDA instruction is used, the RDPUT instruction is executed every scan while the write command is ON. When the LEDB instruction is used, the RDPUT instruction is executed only one scan on the leading edge (OFF → ON) of the write command.

Note that several scans will be required until the completion of write processing by the RDPUT instruction. Therefore, execute the next RDPUT instruction after the completion device has switched on.

(The RDPUT instruction executed before the completion of RDPUT instruction execution is ignored.)

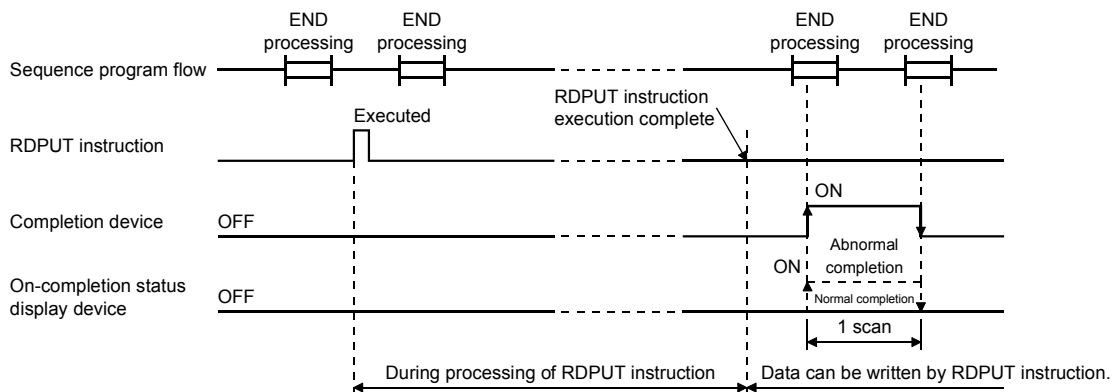

Program Example

The following program writes 1 point of data to the remote device station having station number 1 and connected to the master module of CC-Link allocated to I/O numbers 000 to 01F. This program assumes that control data and written data are stored in D1000-D1004.

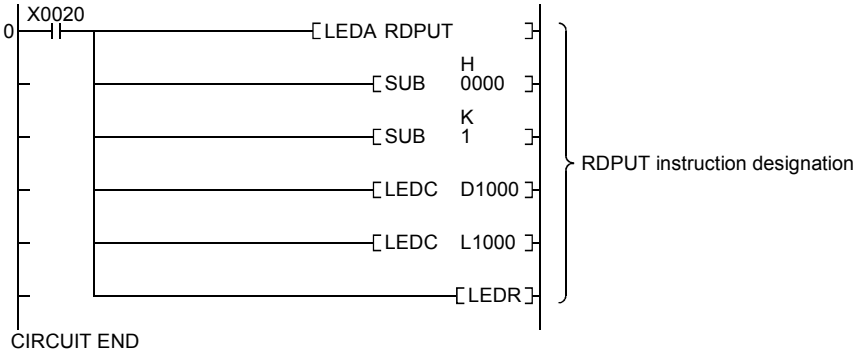

3.12 Monitoring of Remote Device Station RDMON

	Available Devices														Digit designation	Number of steps	Subset	Index	Carry flag	Error flag															
	Bit Device							Word Device													Constant	Pointer	Level												
	X	Y	M	L	S	B	F	T	C	D	W	R	A0	A1										Z	V	K	H	P	I	N					
(n1)																	O	O																	
(n2)																	O	O																	
(D1)								O	O	O	O	O																							
(D2)		O	O	O	O	O																													

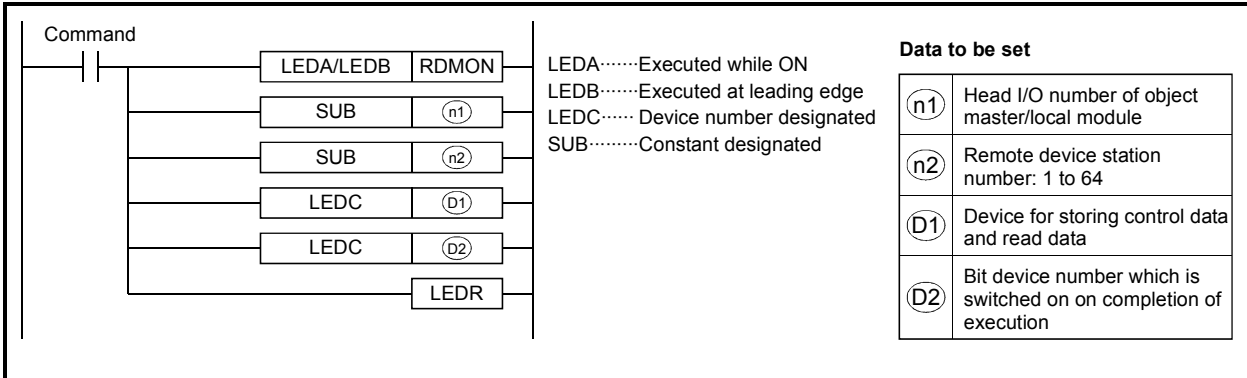

Control Data

(1) Control data setting items

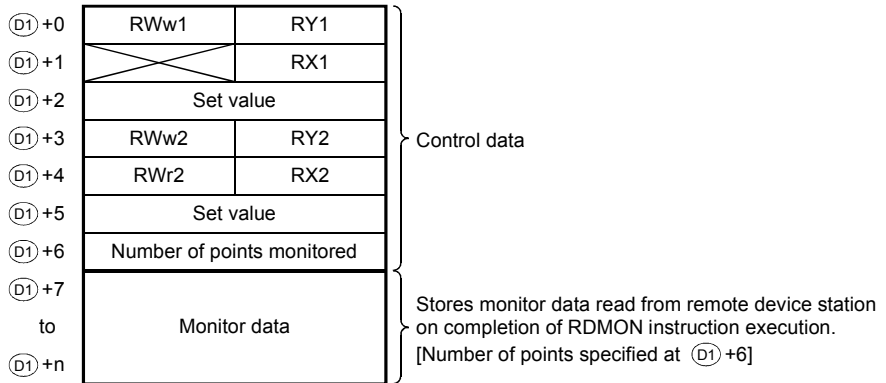

(2) Number of control data area points

Monitor data read from a remote device station is stored into the area after the 7 points of control data [(D1)+0 to (D1)+6].
 Reserve the control data area for 7 points + [number of points specified at (D1)+6] successively.

(3) Control data settings

Item	Set Data	Setting Range	Setting End
RY1	Monitoring registration request	0 to 127 ^{*1}	User ^{*2}
RWw1	Monitoring registration request	0 to 15 ^{*1}	User ^{*2}
RX1	Monitoring registration completion	0 to 127 ^{*1}	User ^{*2}
RY2	Monitoring execution request	0 to 127 ^{*1}	User ^{*2}
RWw2	Monitoring execution request	0 to 15 ^{*1}	User ^{*2}
RX2	Monitoring completion	0 to 127 ^{*1}	User ^{*2}
RWr2	Monitoring completion	0 to 15 ^{*1}	User ^{*2}
Set value	Specify the monitoring set value allocated to the remote device station.	*1	User
Number of points monitored	Specify the number of data monitored (word basis).	1 to 16	User

POINTS

- (1) *1: Refer to the manual of the remote device station from which data is monitored.
- (2) *2: The RY1/2, RWw1/2, RX1/2 and RWr2 numbers used are set by the user.
Note that RY1/2 and RX1/2 ON/OFF control and RWw1/2 and RWr2 data setting are performed by the system.
If the user performs RY1/2 and RX1/2 ON/OFF control and RWw1/2 and RWr2 data setting, the RDMON instruction will not be completed properly.

Functions

- (1) Registers monitoring of the remote device station having the station number specified at (n2) and connected to the master module specified at (n1), and stores the points of monitor data specified at (D1) +6 into the devices starting from the one specified at (D1) +7. On completion of monitor data reading, the bit device specified at (D2) switches on only one scan. On abnormal completion, the bit device at (D2) +1 switches on only one scan.

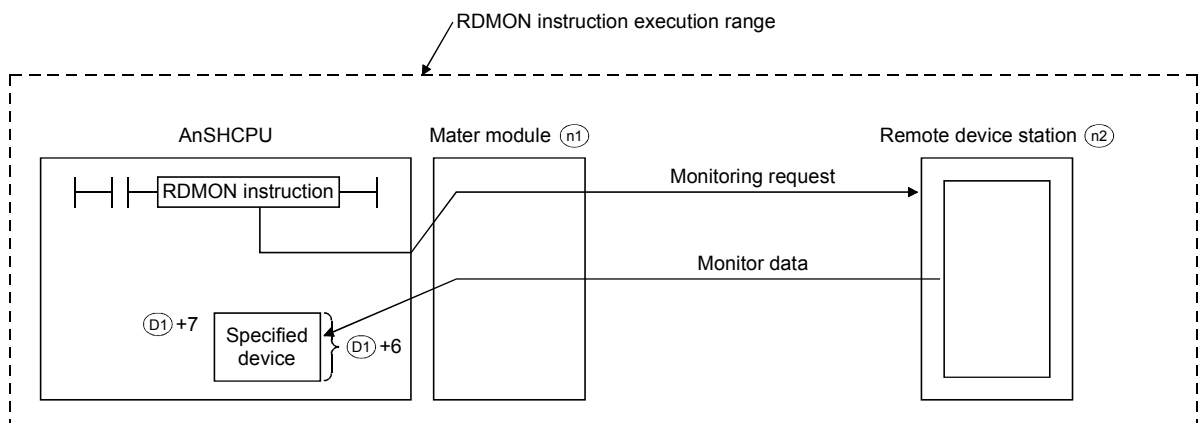

- (2) The RDMON instruction may be executed for two or more remote device stations at the same time. However, this instruction cannot be executed for the same remote device station in two or more locations at the same time.

Execution Conditions

When the LEDA instruction is used, the RDMON instruction is executed every scan while the read command is ON. When the LEDB instruction is used, the RDMON instruction is executed only one scan on the leading edge (OFF → ON) of the read command.

Note that several scans will be required until the completion of read processing by the RDMON instruction. Therefore, execute the next RDMON instruction after the completion device has switched on.

(The RDMON instruction executed before the completion of RDMON instruction execution is ignored.)

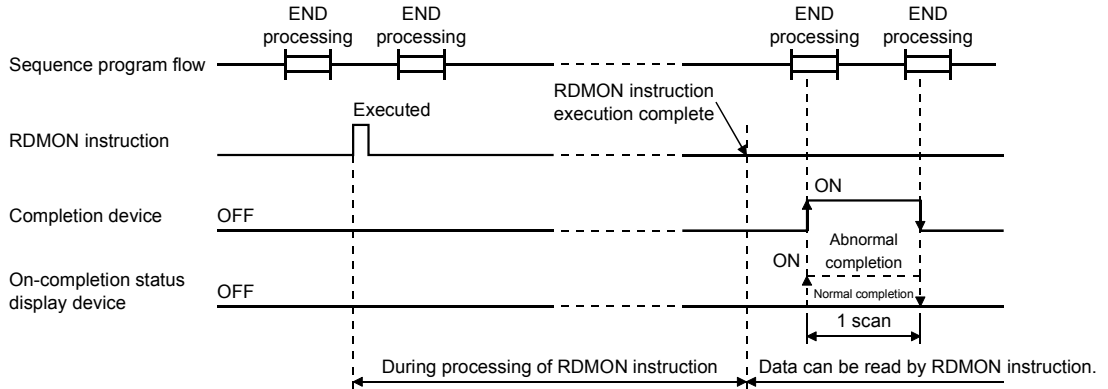

Operation Error

The following condition will result in an operation error and the error flag (M9011) switches on.

Description	Error Code	
	D9008	D9092
The number of read points specified at (D1) +3 is outside the range 0 to 480.	50	503

Program Example

The following program monitors 1 point from the remote device station having station number 1 and connected to the master module of CC-Link allocated to I/O numbers 000 to 01F.

This program assumes that control data are stored in D1000-D1006.

